

**NOBILI** COSTRUZIONI  
MECCANICHE  
PER L'AGRICOLTURA <sup>®</sup>

# Shredders

**VK - VKD**

## OPERATOR'S MANUAL

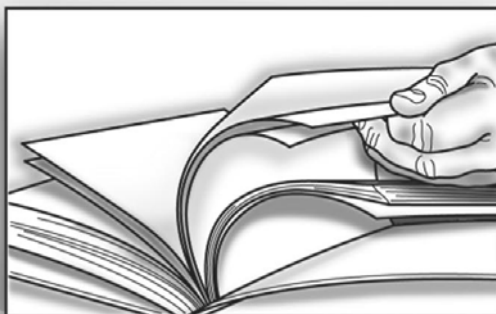

Read carefully before starting the machine

Original instructions



---

# 1. Dear Owner

---

You have purchased a NOBILI machine. Into it have gone years of thought, research and improvement. You will find, as have thousands of owners all over the world, that you have the best that engineering skill and actual field testing can produce. You have purchased a dependable machine, but only through proper care and operation can you expect to receive the performance and long service built into it.

This manual contains all the necessary information for you to receive full efficiency from your machine. The performance you get from this machine is largely dependent on how well you read and understand this manual and apply this knowledge. Please **DO NOT ASSUME YOU KNOW HOW TO OPERATE AND MAINTAIN YOUR MACHINE** before reading this manual carefully. **KEEP THIS MANUAL AVAILABLE FOR REFERENCE.** Pass it on to the next owner if you re-sell the machine.

Your dealer can offer a complete line of genuine NOBILI service parts. These parts are manufactured and carefully inspected in the same factory that builds the machine to assure high quality and accurate fitting of any necessary replacements.

## ■ **About improvements**

We are continually striving to improve our products. We therefore reserve the right to make improvements or changes when it becomes practical to do so, without incurring any obligations to make changes or additions to the equipment sold previously.

## ■ **Wear parts**

Wearing parts fitted on our machines have been tested in very different situations to optimize their service life. Nevertheless, the service life depends highly on the conditions of use (products to handle, soil, weather conditions, etc...).

## ■ **Designated use of the machine**

**VK-VKD** shredders must only be used for the work for which they have been designed: shredding of grass covered areas, maintenance of green spaces, shredding of vine shoots and other pruning residues.

## 2. Contents

<b>1. Dear Owner .....</b>	<b>1</b>
<b>1. Dear Owner 1 .....</b>	<b>2</b>
<b>3. Identification of the machine.....</b>	<b>5</b>
3.1 VK.....	5
3.1.1 Front view .....	5
3.1.2 Rear view.....	5
3.2 VKD .....	6
3.2.1 Front view .....	6
3.2.2 Rear view.....	6
3.3 Model identification plate .....	7
3.4 Optional equipment.....	8
<b>4. Safety.....</b>	<b>9</b>
4.1 Description of symbols used in this document.....	9
4.2 Safety instructions .....	10
4.2.1 Introduction.....	10
4.2.2 Read and follow the safety instructions .....	10
4.2.3 Precautions to be taken before carrying out any operations on the machine.....	11
4.2.4 Precautions to take before using the machine .....	11
4.2.5 Precautions when driving .....	12
4.2.6 Precautions when driving on public roads .....	13
4.2.7 Maximum speed .....	17
4.2.8 Precautions when coupling.....	17
4.2.9 Hydraulic circuit .....	18
4.2.10 PTO shaft.....	19
4.2.11 Precautions during manoeuvres .....	21
4.2.12 Remote controlled components.....	21
4.2.13 Safety decals .....	21
4.2.14 Waste disposal .....	21
4.2.15 Precautions for maintenance and repair work .....	22
4.2.16 Projection of stones and foreign objects.....	23
4.2.17 Precautions for machine use .....	24
4.2.18 Precautions to take to prevent rotor from clogging.....	25
4.3 Location and description of safety decals on the machine .....	26
4.3.1 Location of safety decals .....	26
4.3.2 Description of safety decals.....	28

<b>5.</b>	<b>Machine specifications.....</b>	<b>35</b>
5.1	Description and glossary .....	35
5.2	Technical specifications .....	36
5.3	Required equipment .....	38
5.3.1	Rear support unit.....	38
5.4	Sound levels .....	39
<b>6.</b>	<b>Putting into service.....</b>	<b>40</b>
6.1	Coupling and uncoupling .....	40
6.1.1	Description of coupling elements .....	40
6.1.2	Preparing the tractor.....	40
6.1.3	Preparing the machine .....	41
6.1.4	Coupling the machine.....	42
6.1.5	Primary PTO shaft.....	44
6.1.6	Adjusting the machine .....	46
6.1.7	Uncoupling the machine.....	47
6.1.8	Handling .....	48
<b>7.</b>	<b>Instructions for transport.....</b>	<b>49</b>
7.1	Putting the machine into transport position .....	49
7.2	Conformity with the road regulations .....	49
<b>8.</b>	<b>Instructions for work .....</b>	<b>50</b>
8.1	Putting the machine into work position .....	50
8.2	Adjustments in working position .....	51
8.2.1	Working height .....	51
8.2.2	Height of the tractor's lift linkage .....	51
8.3	Machine use .....	52
8.3.1	Rear hood.....	53
8.3.2	Drive speed .....	53
<b>9.</b>	<b>Optional equipment .....</b>	<b>54</b>
9.1	Skids.....	54
9.1.1	Mounting and adjustment.....	54
9.2	Support wheel.....	55
9.2.1	VK.....	55
9.2.2	VKD .....	56
9.3	Roller .....	59
9.3.1	Adjustments.....	59
9.3.2	Machine use .....	60
9.3.3	Maintenance.....	60

9.4	Collecting tines .....	61
9.4.1	Height adjustment.....	61
9.4.2	Machine use .....	61
9.5	Lighting and signalling .....	62
9.6	Hydraulic offset .....	63
9.6.1	Hydraulic connection .....	63
9.6.2	Putting the machine into transport position .....	63
9.6.3	Machine use .....	63
9.7	Mow-around disk (VKD).....	64
9.7.1	Identification .....	64
9.7.2	Safety instructions .....	65
9.7.3	Machine specifications .....	67
9.7.4	Putting into service .....	69
9.7.5	Instructions for transport.....	71
9.7.6	Instructions for work .....	71
9.7.7	Maintenance and storage .....	72
<b>10.</b>	<b>Maintenance and storage .....</b>	<b>76</b>
10.1	Frequency chart.....	76
10.2	Cleaning the machine .....	78
10.3	Lubrication .....	78
10.3.1	PTO shaft.....	78
10.3.2	Grease.....	79
10.3.3	Oil change .....	80
10.4	Maintenance .....	81
10.4.1	Checking the oil levels.....	81
10.4.2	Check cutting tools and their fixing elements .....	82
10.4.3	Belt tension.....	86
10.5	Storage .....	89
10.5.1	At the end of each season.....	89
10.5.2	At the start of each season.....	90
10.6	Machine recycling .....	90
<b>11.</b>	<b>Troubleshooting guide.....</b>	<b>91</b>
<b>12.</b>	<b>Appendix .....</b>	<b>93</b>
12.1	Calculating the load on an axle.....	93
<b>13.</b>	<b>Limited Warranty .....</b>	<b>101</b>

---

## 3. Identification of the machine

---

---

### 3.1 VK

---

#### 3.1.1 Front view

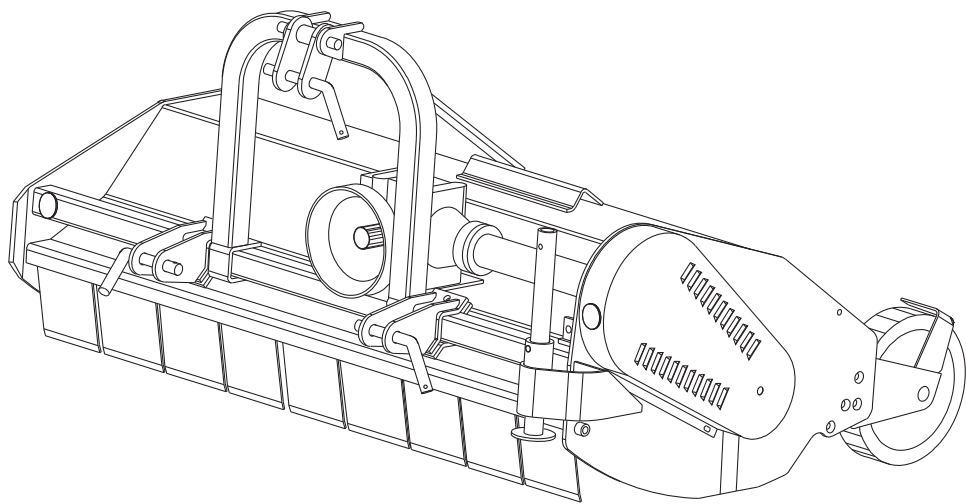

#### 3.1.2 Rear view

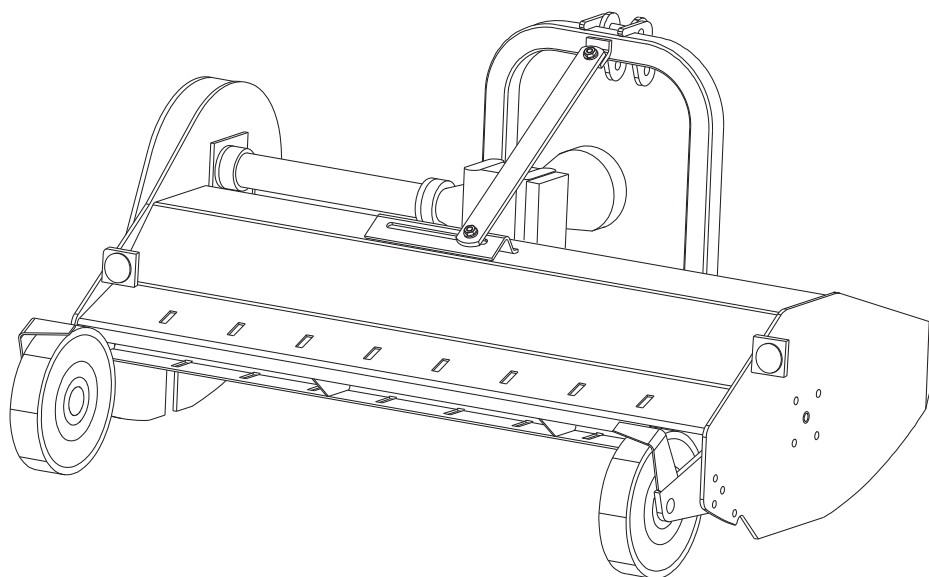

---

## 3.2 VKD

---

### 3.2.1 Front view

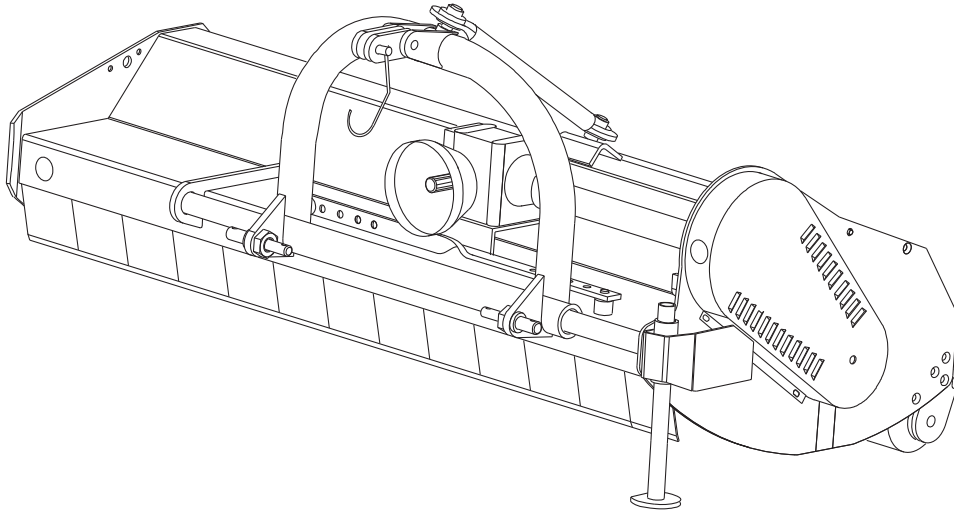

### 3.2.2 Rear view

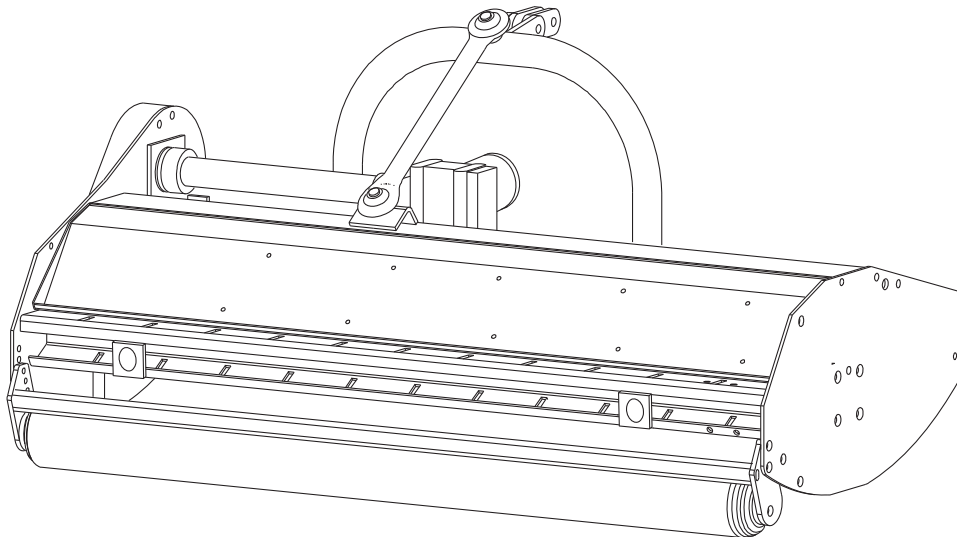





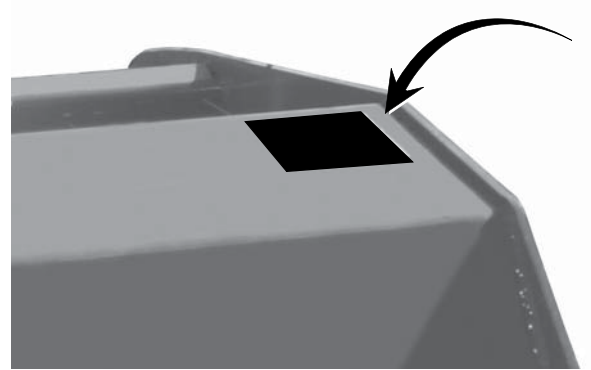

### 3.3 Model identification plate

Please write below the type and serial number of the machine. This information is to be given to your NOBILI dealer for all parts order or warranty claim.



- Type: VK
- Serial no.:
  
- Type: VKD
- Serial no.:

	<b>NOBILI</b> ® COSTRUZIONI MECCANICHE PER L'AGRICOLTURA <small>s.p.a. - 40062 MOLINELLA (BO) ITALIA -</small>		
<b>TRINCE BROYEURS TRITURATOR MULCHER</b>	BLASIA 220 (ISO 220)	SUPERTRACTOR UNIVERSAL 15W/40	MU / EP2
Mod. : <input type="text"/>			
Num. : <input type="text"/>	<b>LUBRIFICANTI CONSIGLIATI</b> LUBRIF. ACONSEJADOS - RECOMMENDED LUBRICANTS EMPFOHLENE OEL/FETTE - LUBRIFIANTS CONSEILLES		
Data : <input type="text"/>			
Massa Kg : <input type="text"/>			

---

### 3.4 Optional equipment

---

Tick box corresponding to the equipment fitted on your machine:

- Skids.
  - Support wheel.
  - Roller .
  - Collecting tines.
  - Lighting and signalling.
  - Hydraulic offset.
  - Mow-around disk (VKD).
-

---

## 4. Safety

---

---

### 4.1 Description of symbols used in this document

---

This symbol indicates a potentially hazardous situation that if not avoided, could result in serious bodily injury.



This symbol is used to identify special instructions or procedures which, if not followed strictly, could result in machinery damage.



This symbol is used to communicate technical information of particular interest.



---

## 4.2 Safety instructions

---

### 4.2.1 Introduction

The machine must only be operated, maintained and repaired by competent persons who are familiar with machines' specifications and operation and aware of safety regulations for preventing accidents.

The operator must imperatively respect safety instructions in this manual and in the warnings posted on the machine. The operator is also obliged to respect current legislation concerning accident prevention, work safety and public traffic circulation.

Designated use of the machine also means following operation, maintenance and repair recommendations given by the manufacturer, and using only genuine spare parts, equipment and accessories, as recommended by the manufacturer.

The manufacturer is not held liable for any damage resulting from machine applications other than those specified by the manufacturer. Any use other than the designated operation is at the risk and responsibility of the operator.

The manufacturer is not held liable for any damage or accident resulting from machine modifications carried out by the operator himself or by a third party without previous written agreement from the manufacturer.

---

### 4.2.2 Read and follow the safety instructions

Before using the machine, carefully read all the safety instructions in this manual and the warnings placed on the machine.

Before starting work, the operator must be familiar with all machine controls, handling devices and their functions. It is too late to learn once work has been started!

Never let anyone operate the machine who is not trained to do so.

Should you have any difficulties in understanding any parts of this manual, please contact your NOBILI dealer.

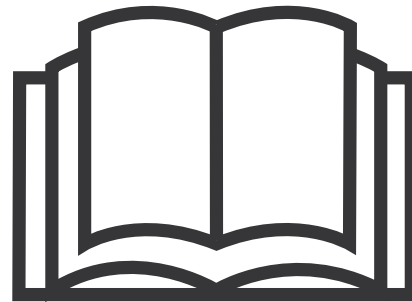

### 4.2.3 Precautions to be taken before carrying out any operations on the machine

Before leaving the tractor or before adjusting, maintaining or repairing the machine, disengage the PTO drive, turn off the engine, remove ignition key and wait until all moving parts have come to a complete stop and apply park brake.



### 4.2.4 Precautions to take before using the machine

Do not wear loose clothing which could become caught up in moving parts.

Wear the appropriate protective clothing for the work in hand (gloves, shoes, goggles, helmet, ear defenders, etc.).

Ensure that all operating controls (ropes, cables, rods, etc) are placed so as they cannot be operated unintentionally and cause damage or injury.

Before operating the machine, check tightness of nuts and bolts, particularly on fixing elements (tines, forks, blades, knives, etc). Retighten if necessary.

Before operating the machine, ensure that all the safety guards are firmly in place and in good condition. Immediately replace any worn or damaged guard.



#### 4.2.5 Precautions when driving

Tractor handling, stability, performance and braking efficiency are all affected by weight distribution, trailed or mounted implements, additional ballast and driving conditions. It is therefore of great importance that the operator exercises caution in every given situation.

Groundspeed must be adapted to ground conditions as well as to roads and paths. Always avoid abrupt changes of direction.

Be particularly cautious when turning corners, paying attention to machine overhang, length, height and weight.

Never use a narrow track tractor on very uneven or steeply sloping ground.

Never leave the tractor seat while the machine is operating.

Carrying people or animals on the machine when working or in transport is strictly forbidden.

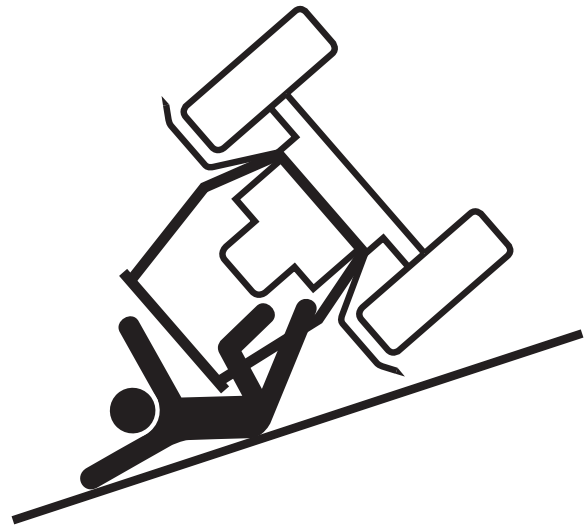

## 4.2.6 Precautions when driving on public roads

### ■ Dimensions

Depending on the dimensions of the machine, contact the relevant authorities to ensure that it can be legally transported on public roads.

If the machine is over the maximum legal size, follow the local regulations for special transportation of oversize equipment.

### ■ Transport position

Before transporting the machine on public roads, place the machine into its transport position, according to the instructions in this manual.

### ■ Lights and indicators

Before transporting the machine on public roads, ensure that all legally required lightings and signalings are in place.

Ensure that lightings and signalings are clean and in good working order. Replace any missing or broken equipment.

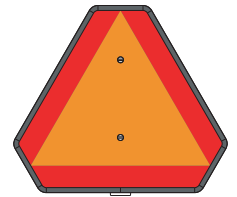
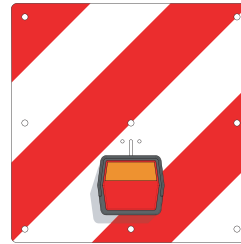

**Always obey current regulations for driving on roads.**

■ **Gross weight and weight per axle**



The drawings are not legally binding, their only aim is to illustrate the method to use.

**Prior to driving on public roads, check that all criteria are met to be in conformity with the country's regulations:**



- When coupling a tool to the front and/or rear 3-point lift linkage, the maximum authorized payload must not be exceeded.
- When coupling tools to the front and/or rear 3-point lift linkages, the maximum load on tractor's tires must not be exceeded.
- The load on the tractor front axle must always represent 20 % of the tractor unladen weight.



**For machines with hoppers or tanks:**

- If the total unit weight exceeds the tractor Gross Combined Weight Rating in accordance with the country's legislation, empty the hopper to travel on public roads.
- In any case, we recommend to travel on public roads with empty hoppers and tanks.

**Description of symbols**

Description	Units	Description
T	kg	Tractor unladen weight
PTAC	kg	Gross Combined Weight Rating
T1	kg	Unladen load on tractor front axle
T2	kg	Empty load on tractor rear axle
t	kg	Axle loads (Tractor + machine)
t1	kg	Load on front axle (Tractor + machine)
t2	kg	Load on rear axle (Tractor + machine)
t1 max	kg	Maximum load authorized on the tractor front axle according to the tires
t2 max	kg	Maximum load authorized on the tractor rear axle according to the tires
M1	kg	Total weight of rear tool or rear ballast



**How to proceed:**

**Stage 1:**

To measure:

- Tractor tare (T).

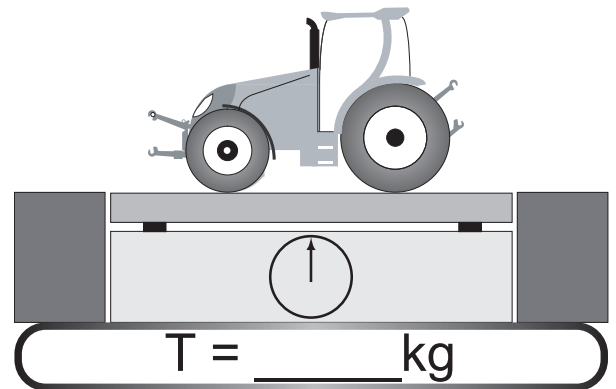

**Stage 2:**

- Couple the machine to the tractor.

To measure:

- Load on front axle (t1):
  - Tractor + machine (transport position).

To do:

- If the front axle load (t1) is below 20% of the tractor tare (T), add ballast weights (M1) to exceed the minimum load on the front axle.

Example:

- (T) = 7500 kg (16535 lb)
- The front axle load must be of minimum 1500 kg (3300 lb). (20% of T)
- (t1) = 700 kg (1545 lb).
- 700 kg (1545 lb) < 1500 kg (3300 lb).
- Add ballast weights until the minimum front axle load is exceeded.
- Repeat checking procedure.

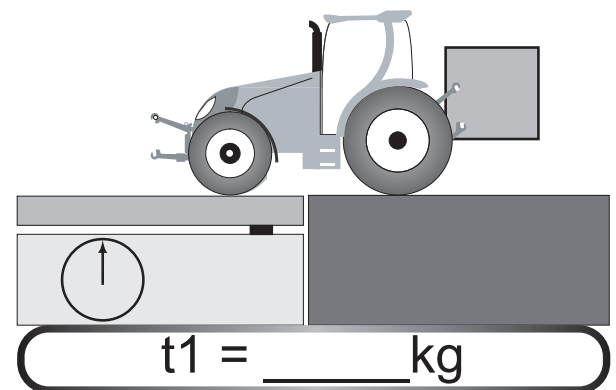

$t1 < 20\% T \rightarrow \times$

$t1 \geq 20\% T \rightarrow \checkmark$

**Stage 3:**

To measure:

- Total weight (t):
  - Tractor + machine (transport position).
  - Ballast weights.

Checking:

- To go to the next stage:
  - Check in the tractor's operator's manual that the value measured is below the tractor's Gross Combined Weight Rating.

To do:

- If  $t < PTAC$  go to the next stage.
- If the total unit weight exceeds the tractor Gross Combined Weight Rating in accordance with the country's legislation, empty the hopper to travel on public roads.
- Repeat checking procedure.

Example:

- $(t) = 10000 \text{ kg} (24250 \text{ lb})$
- $PTAC = 13000 \text{ kg}$ .
- $t < PTAC$  : Go to the next stage.

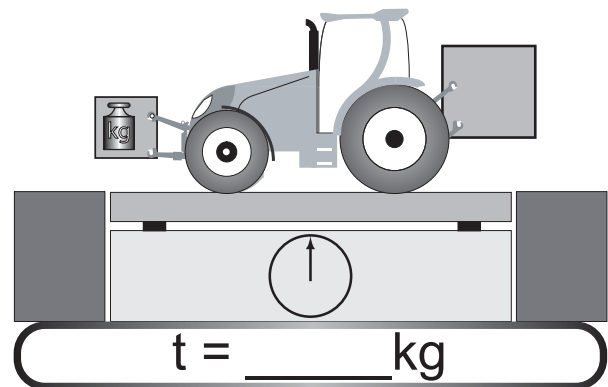

**Stage 4:**

To measure:

- Load on rear axle ( $t_2$ ):
  - Tractor + machine (transport position).
  - Ballast weights.

Checking:

- Check in the tractor's operator's manual that the value measured is below the maximum allowed tractor rear axle load.
- Check that tyre and rim specifications are in conformity with the requirements of the tractor manufacturer.

Example:

- Load on rear axle ( $t_2$ ) =  $8500 \text{ kg} (18740 \text{ lb})$
- Check in the tractor's operator's manual that the value measured is below the maximum allowed tractor rear axle load.
- Check that tyre and rim specifications are in conformity with the requirements of the tractor manufacturer.

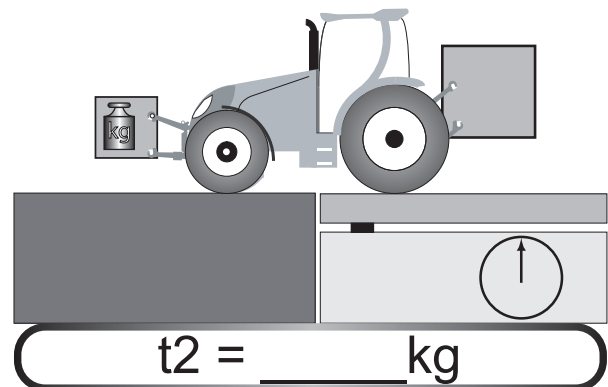

$t_2 > t_2 \text{ max}$  → ✘

$t_2 \leq t_2 \text{ max}$  → ✔

#### 4.2.7 Maximum speed

- Always keep to the legal speed limit for driving a tractor-machine assembly on public roads.

#### 4.2.8 Precautions when coupling

Before attaching the machine, make sure that it cannot accidentally start moving (chock the wheels) and that the parking stand is in the right position.

The machine must only be attached to the hitch points provided for this purpose.

Never stand between the tractor and the machine when operating the three point linkage.

Do not stand between the tractor and the machine without ensuring that the parking brake is applied.



#### 4.2.9 Hydraulic circuit

Caution! The hydraulic circuit is under high pressure. Maximum pressure at work: 200 bar.

Before connecting hoses to the tractor hydraulics, ensure that tractor and machine circuits are not under pressure. Before disconnecting a hose, depressurize the hydraulic circuit.

To avoid making incorrect connections, mark hydraulic couplers and corresponding hoses with colors. **WARNING!** Functions could be reversed (for example: lift/lower) and cause accidents.

Regularly check the hydraulic hoses. In case of normal wear, replace the hydraulic hoses every 5 years. Damaged or worn hoses must immediately be replaced. When replacing the hydraulic hoses, only use hoses with the specification recommended by the manufacturer of the machine.

To locate a leak, use appropriate means. Protect body and hands from liquid under pressure.

Any liquid under pressure (particularly oil from hydraulics) can penetrate the skin and cause severe injury. If injured, see a doctor immediately, there could be danger of infection.

Before any adjustments, maintenance or repairs are carried out, lower the machine to the ground, depressurize the hydraulics, turn off the engine, remove ignition key and wait until all moving parts have come to a complete stop.



#### 4.2.10 PTO shaft

Use only PTO shafts supplied with the machine or recommended by the machine manufacturer.

The protective shield of the tractor PTO stub, the PTO shaft guards and the protective shield of the machine input shaft must always be in place and in good condition.

Make sure that the PTO shaft guards are secured with the safety chains provided. Check that the PTO shaft guard can turn freely a full rotation independent of the shaft.

Any worn or damaged guards must be replaced immediately. A worn guard or an unprotected PTO shaft can cause a serious or even a lethal accident.

Do not wear loose clothing that could be caught in the rotating PTO shaft.



Before attaching or removing a PTO shaft, or before doing any work on the machine, disengage the PTO drive, turn off the engine, remove ignition key and wait for all moving parts to come to a complete stop.

If the primary PTO shaft is equipped with a torque limiter or a free wheel, these must be fitted on the machine side.

Ensure that the PTO shaft is always correctly fitted and locked into place.

Before connecting the PTO shaft, ensure that the PTO speed (rotational frequency) and direction of rotation are in line with the machine manufacturer's recommendations.

Before engaging the PTO drive, make sure that there are no people or animals near the machine. Never engage the PTO drive when the tractor engine is stopped.

Do not install any adapter device that results in a portion of the tractor PTO stub, the rotating PTO shaft, or the adapter to be unguarded. The tractor master shield shall overlap the end of the splined shaft and the added adaptor device as outlined in the table.

When uncoupling the machine, rest the PTO shaft on the support specially provided, and replace protective shield on the PTO stub of the tractor.

Read and follow the instructions in the operator's manual provided with the PTO shaft.

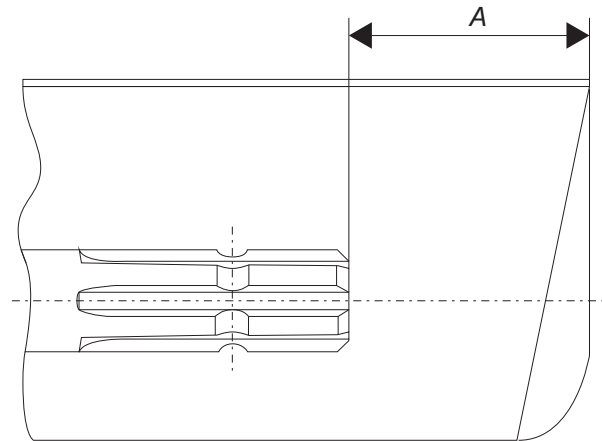

PTO type	Diameter	X splines	A ± 5 mm (0.20")
1	35 mm (1.378")	6	85 mm (3.35")
2	35 mm (1.378")	21	85 mm (3.35")
3	45 mm (1.772")	20	100 mm (4.00")

#### 4.2.11 Precautions during manoeuvres

When moving the machine from the transport position to the working position and vice versa, make sure that nobody is within the machine pivoting area.

---

#### 4.2.12 Remote controlled components

Danger of crushing and shearing can exist when components are operated by hydraulic or pneumatic controls. Keep away from these danger zones.

---

#### 4.2.13 Safety decals

Safety warning decals are placed in pictorial form on various parts of the machine. They are there to warn you of potential dangers and to tell you how to avoid accidents.

Always keep the safety decals clean and readable, and replace them when they are worn, damaged, missing or illegible.

---

#### 4.2.14 Waste disposal

Respect the environment! Never spill pollutants (oil, grease, filters, etc.) on the ground, never pour them down the drain and never discard them in any other place where they could pollute the environment. Never throw away or burn a tyre. Always take waste to specialized recycling or waste disposal centers.

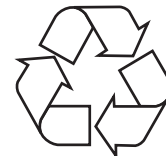

#### 4.2.15 Precautions for maintenance and repair work

Before leaving the tractor or before adjusting, maintaining or repairing the machine, disengage the PTO drive, turn off the engine, remove ignition key and wait until all moving parts have come to a complete stop and apply park brake.

Rest the machine on the ground, release the pressure from the hydraulic circuit and leave the machine to cool down.

Make sure that the parts of the machine that need to be lifted for maintenance or repair work are firmly propped up.

Before any work is done on the electric circuit or before any electric welding is carried out on the attached machine, disconnect the machine from the tractor electrical circuit. Also disconnect alternator and battery terminals.

Repairs on elements under pressure or tension (springs, pressure accumulators, etc.) must only be carried out by competent persons with regulation equipment.

Wear the appropriate protective clothing for the work in hand (gloves, shoes, goggles, helmet, ear defenders, etc.).

Do not solder, weld or use a blow torch near fluids under pressure or inflammable products.

For your own safety and for correct machine operation, only use original manufacturer parts.

It is strongly recommended to have your machine checked by your NOBILI dealer after each season, especially tools and their attaching hardware.





#### 4.2.16 Projection of stones and foreign objects

For driver safety, always use a tractor equipped with a cab. Keep the ground to be shredded free from foreign objects. Avoid using the shredder on stony or rocky ground. If this is not possible, take extra safety precautions, such as:

- Fit polycarbonate screens inside the tractor cab's side and rear windows, or install narrow mesh guards on their exterior.
- Increase the cutting height to avoid contact with stones or rocks.

Never start the shredder when there are people nearby.

Even when the machine is used in accordance with its purpose, objects may be projected. Stones and other foreign objects projected by the moving parts can travel a considerable distance. Keep all persons and animals away from the danger zone.

The guard plates/covers on the machine help reduce the risks of projection. Therefore, make sure that all shredder protection devices are in place and good condition prior to using the machine.

Regularly check the condition of the guard plates/covers. Immediately replace any worn, damaged or missing guard plate/cover.



#### 4.2.17 Precautions for machine use

After each use, check the seeding tools (shares, coulters) and their attachment hardware in accordance with the instructions given in the present manual. Immediately replace any worn, damaged or missing guard plate/cover. Before engaging the pto drive, lower the shredder onto the ground. For your safety, only use genuine parts !

Regularly check the condition of the guard plates/covers. Immediately replace any worn, damaged or missing cover. Before engaging the PTO drive, lower the machine on the ground. Make sure all the guards are in place. Keep all persons and animals away from the danger zone.

Stay a safe distance from the machine when the cutting tools are in movement.

Never work in reverse.

After disengaging the PTO drive, cuttings tools can continue rotating for some time. Stay away from the machine until all moving parts have come to a complete standstill.

If the machine hits an obstacle, disengage the PTO drive, stop the tractor engine, remove the ignition key and wait for all moving parts to come to a complete standstill. Check the entire machine for any damage before resuming work.

#### **4.2.18 Precautions to take to prevent rotor from clogging**

Foreign bodies in the field (wire,...) can cause clogging.

Avoid shredding close to roads, dumps or inert material dumps.

To eliminate cloggings, take the following safety measures:

- Switch off the engine.
  - Lift the machine using the tractor's lift linkage.
  - Put on gloves and protective glasses.
  - Wait until all rotating parts have come to a complete stop.
  - Checked concerned parts for overheating.
  - Prop up frame using trestles.
  - Remove foreign body with adequate equipment (lever and pliers).
-

## 4.3 Location and description of safety decals on the machine

### 4.3.1 Location of safety decals

■ VK

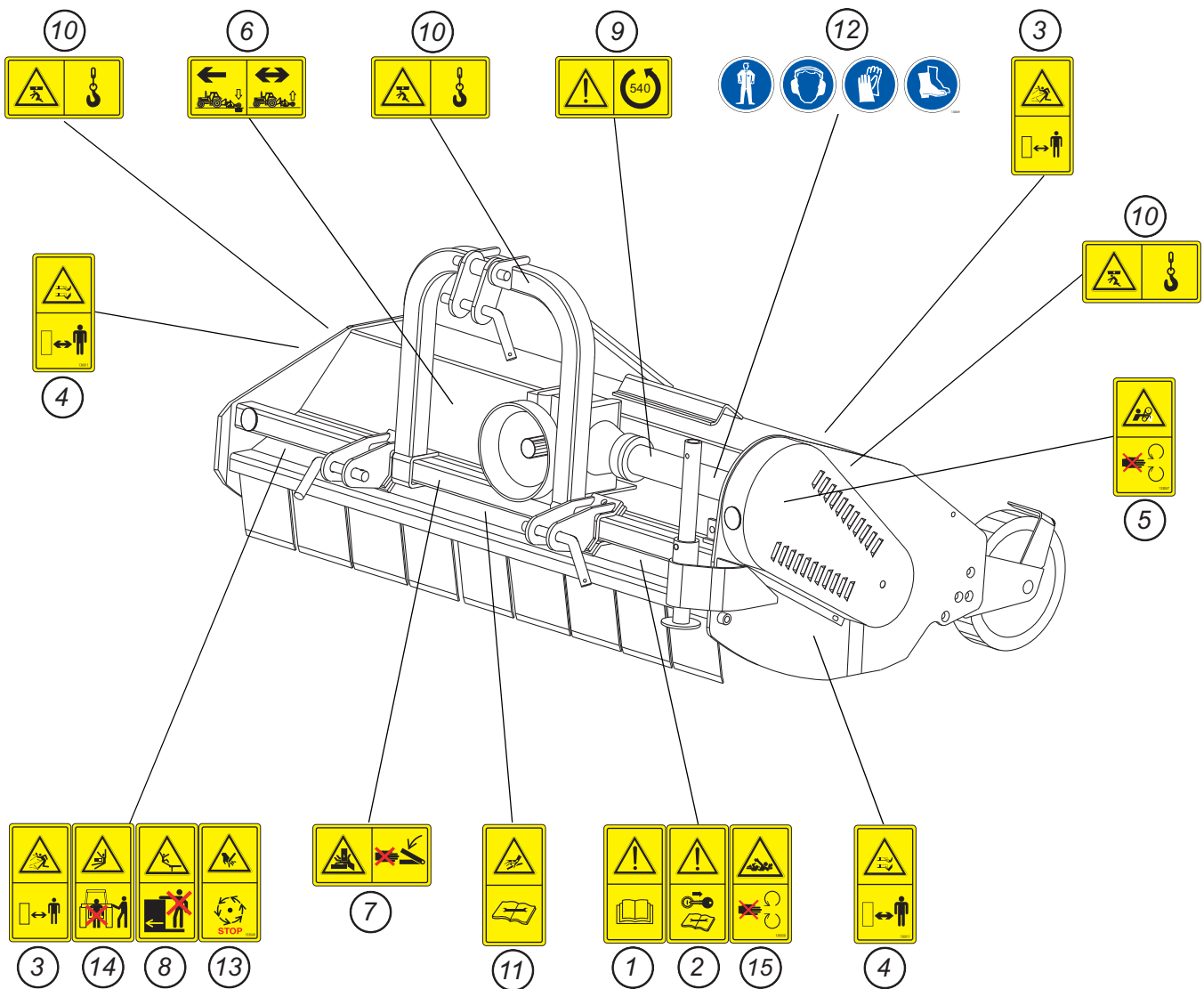



### 4.3.2 Description of safety decals

#### ■ Operating instructions (1)

The operators' manual contains all the information necessary for using the machine safely. It is imperative to read and comply with all instructions.



#### ■ Working on the machine (2)

Before leaving the tractor or before adjusting, maintaining or repairing the machine, disengage the PTO drive, turn off the engine, remove ignition key and wait until all moving parts have come to a complete stop and apply park brake.

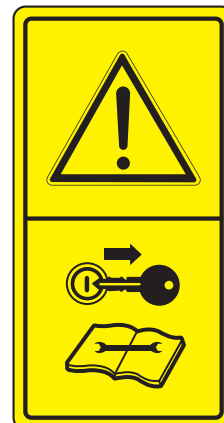

■ **Projections (3)**

Stones and other debris projected by the moving parts can travel a long distance. The guard plates/covers must always be in position and in good condition. Always stay at a safe distance from the machine.



■ **Rotating cutting tools (4)**

Keep away from the machine tools all the time the engine is running, the PTO drive engaged and the moving parts have not come to a complete stop.



■ **Moving elements (5)**

Do not open or remove guards when the engine is running.



■ **Support wheels (6)**

At work, the support wheels must rest on the ground. During manoeuvres, raise the machine to lift the wheels off the ground.

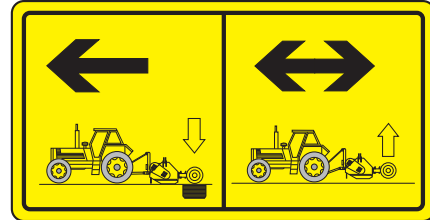

■ **Crushing area (7)**

Never operate in an area where there is a crushing risk before all moving parts have come to a complete stop .



■ **Danger of falling (8)**

Do not ride on the machine.





■ **Power requirement (9)**

Machine preset for a 540 min<sup>-1</sup> drive.



■ **Anchoring point 10**

Indicates anchoring points for handling the machine.



■ **Hazard: high-pressure fluids (11)**

Oil jets under pressure.



■ **Use of guards (12)**

Wear the appropriate protective clothing for the work in hand (gloves, shoes, goggles, helmet, ear defenders, etc.).



■ **Risk of injuries (13)**

Before adjusting, maintaining or repairing the machine, wait until all moving parts have come to a complete stop.



■ **Risk of being crushed (14)**

Do not stay between the machine and the tractor.



■ **Risk of entanglement (15)**

Stay clear of rotating drive line.



## 4.4 Road safety equipment and recommendations

The road safety equipment is mounted in the factory or by your NOBILI dealer according to current safety regulations. Always keep to the legal speed limit for driving a tractor-machine assembly on public roads.

The rear safety device comprises:

- 2 red reflectors (1).

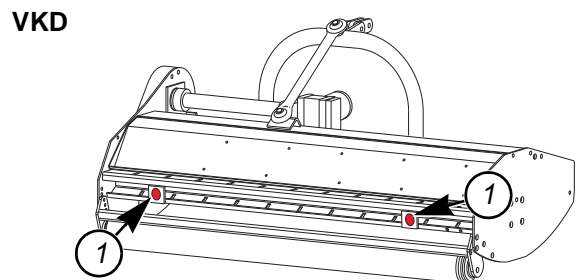
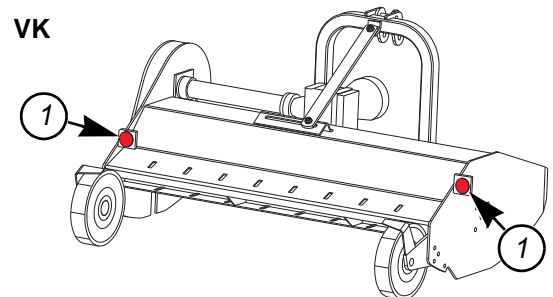

The front safety device comprises:

- 2 white reflectors (1).

VK

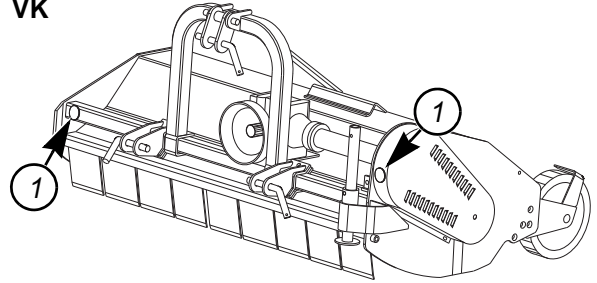

VKD

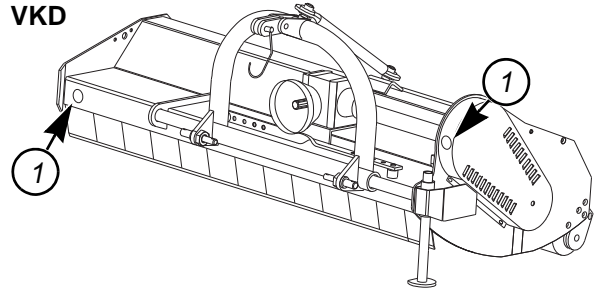

---

## 5. Machine specifications

---

---

### 5.1 Description and glossary

---

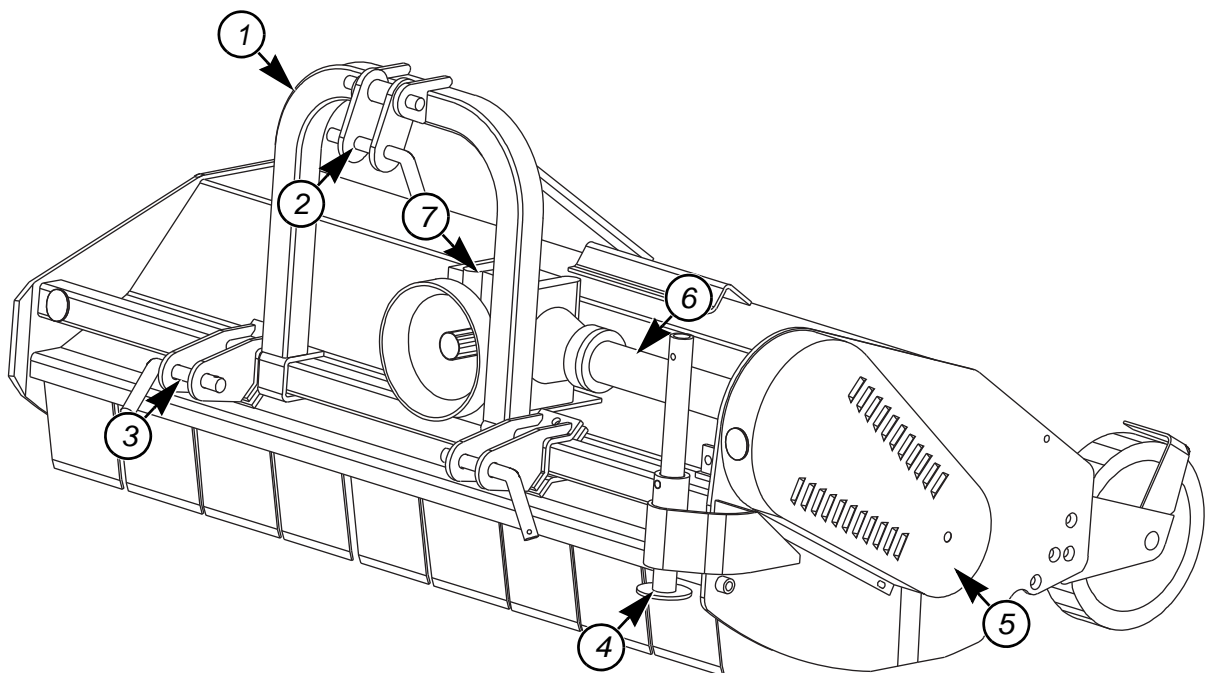

1 : Three-point hitch coupler  
3 : Hitch pins  
5 : Side guard  
7 : Central gearbox

2 : Hitch frame  
4 : Parking stand  
6 : Side drive shaft

## 5.2 Technical specifications

### ■ VK

		95	115	135	155	
<b>Coupling device</b>		3 point linkage category 1 and 2				
<b>Lateral offset</b>		95 mm (3.74")		200 mm (7.87")		
<b>Working width</b>		966 mm (3'02")	1154 mm (3'09")	1342 mm (4'05")	1530 mm (5')	
<b>Maximum width</b>		1078 mm (3'06")	1266 mm (4'02")	1474 mm (4'10")	1662 mm (5'05")	
<b>Minimum PTO power requirement</b>		26 kW (35 hp)	29 kW (40 hp)	33 kW (45 hp)	37 kW (50 hp)	
<b>Maximum allowable PTO power</b>		51 kW (70 hp)				
<b>Free wheel</b>		Inside central gearbox				
<b>Power takeoff rotation frequency</b>		540 min <sup>-1</sup>				
<b>Quantity / type of belts</b>		2 / SPBX 1270	2 / SPBX 1270	3 / SPBX 1270	3 / SPBX 1270	
<b>Rotor speed</b>		2218 min <sup>-1</sup>				
<b>Knives peripheral speed</b>		46.2 m/s				
<b>Number of knives</b>	<b>Type 01</b>	Universal knives	20	24	28	32
	<b>Type 06</b>	Hammer knives	10	12	14	16
<b>Weight</b>		290 kg (639 lb)	330 kg (728 lb)	365 kg (805 lb)	400 kg (882 lb)	

■ VKD

	155	170	190	210	230		
<b>Coupling device</b>	3 point linkage category 1 and 2						
<b>Lateral offset</b>	350 mm (1'1.8")			450 mm (1'5.7")			
<b>Working width</b>	1530 mm (5')	1718 mm (5'08")	1906 mm (6'03")	2094 mm (6'10")	2282 mm (7'6")		
<b>Maximum width</b>	1665 mm (5'06")	1852 mm (6'01")	2040 mm (6'08")	2230 mm (7'04")	2418 mm (7'11")		
<b>Minimum PTO power requirement</b>	37 kW (50 hp)	44 kW (60 hp)	48 kW (65 hp)	51 kW (70 hp)	55 kW (75 hp)		
<b>Maximum allowable PTO power</b>	74 kW (100 hp)						
<b>Free wheel</b>	Inside central gearbox						
<b>Power takeoff rotation frequency</b>	540 min <sup>-1</sup>						
<b>Quantity / type of belts</b>	3 / SPBX 1500			4 / SPBX 1500			
<b>Rotor speed</b>	2325 min <sup>-1</sup>						
<b>Knives peripheral speed</b>	51.5 m/s						
<b>Number of knives</b>	Type 01	Universal knives	32	36	40	44	48
	Type 06	Hammer knives	16	18	20	22	24
<b>Weight</b>	510 kg (1124 lb)	560 kg (1235 lb)	600 kg (1323 lb)	640 kg (1411 lb)	715 kg (1576 lb)		

## 5.3 Required equipment

### 5.3.1 Rear support unit

#### Roller

The roller can be used for work on grass covered areas, set-aside land or pasture land.

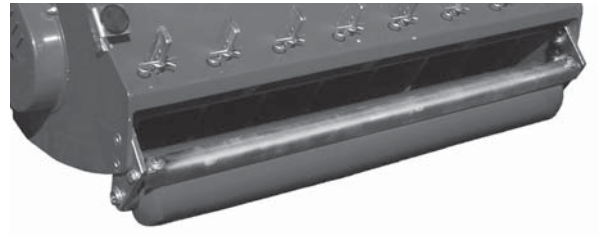

or

#### Support wheels Iron (VK)

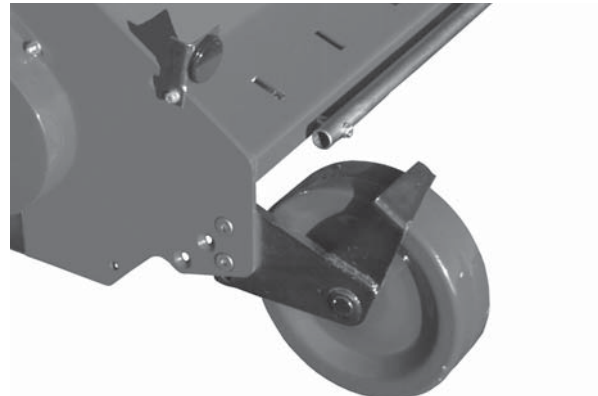

or

#### Support wheels Tyres (VKD)



*The semi-pivoting wheels are recommended for work in wet conditions.*



## 5.4 Sound levels

Sound levels have been measured in accordance with the measuring methods as defined in:

**EN ISO4254-1: 2009**

«Agricultural machines - Self-propelled, mounted, semi-mounted and trailed - Common safety recommendations»

Weighted equivalent continuous acoustic pressure level at the driver's seat (closed cabin) **L(A)<sub>eq</sub>** according to standard **UNI EN ISO 11201**

- VK 95-115-135-155: **76.4 dB(A)**
- VKD 155-170-190-210-230: **77.6 dB(A)**

Measured weighed volume level **L<sub>w</sub>(A)** according to standard **UNI EN ISO 3744: 1997** for machines that exceed a pressure of 80dB(A) in the driver's post:

- VK 95-115-135-155: **77.1 dB(A)**
- VKD 155-170-190-210-230: **78.2 dB(A)**



**Wear ear protectors!**



## 6. Putting into service

### 6.1 Coupling and uncoupling

#### 6.1.1 Description of coupling elements

- A PTO shaft 1 3/8" - 6 splines (1).
- A category 1 and 2 three point hitch coupler.

#### 6.1.2 Preparing the tractor



The tractor must be fitted with lower link stabilizers.



Check that the tractor's authorized gross weight as well as its lift capacity and maximum weight per axle are not exceeded:

See section:

- Safety / Safety instructions / Precautions when driving on public roads.
- Appendix

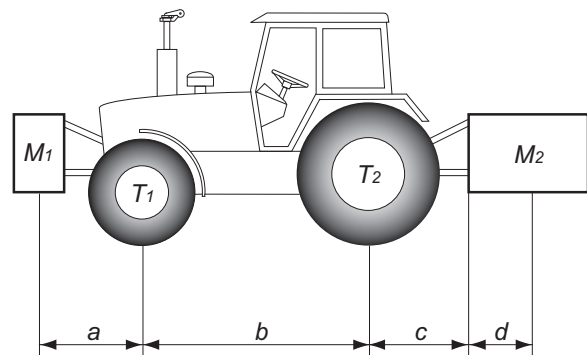

The tractor PTO stub must rotate at a speed of 540 min<sup>-1</sup>.

■ **Hitch pin parallelism**

- Adjust tractor lift rods so that hitch pins are parallel to the ground.

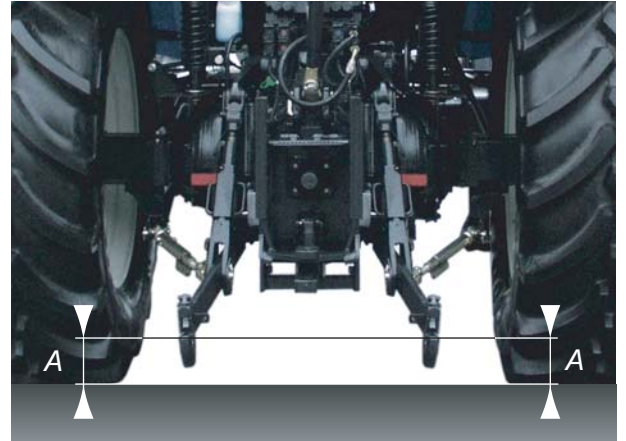

**6.1.3 Preparing the machine**

- Check the speed preset by the manufacturer through the stickers on the machine.

■ **Axial offset position**

The attachment is factory fitted in central position.



*When optional equipment is used, follow specific procedures mentioned in the related section:*

- Hydraulic offset.

**VK**

- Unscrew the 3 nuts (1).
- Position hitch frame in the required position.
- Tighten the 3 nuts (1).

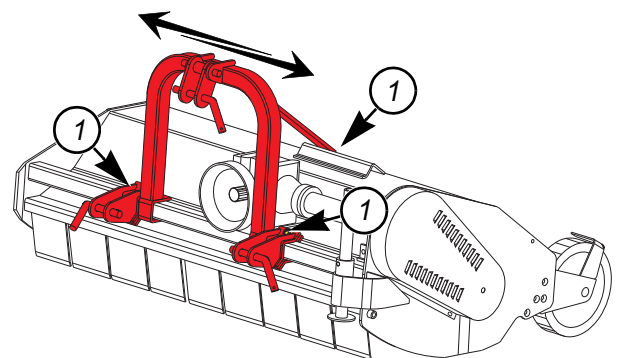

**VKD**

- Remove the offset adjustment bar (1).
- Position hitch frame in the required position.
- Reinstall offset adjustment bar (1).

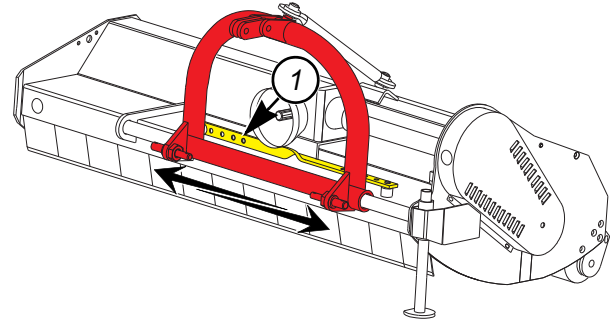

**6.1.4 Coupling the machine**



*When optional equipment is used, follow specific procedures mentioned in the related section:*

- Hydraulic offset.

**VK**

- Lower the tractor three-point linkage.
- Place the lower links as close as possible under the hitch pins.
- Attach the lower links to the hitch pins.



*Position the 3 bushes (1) on lower hitch pins when the machine is coupled to a tractor fitted with a standardized 3 point attachment category 2*

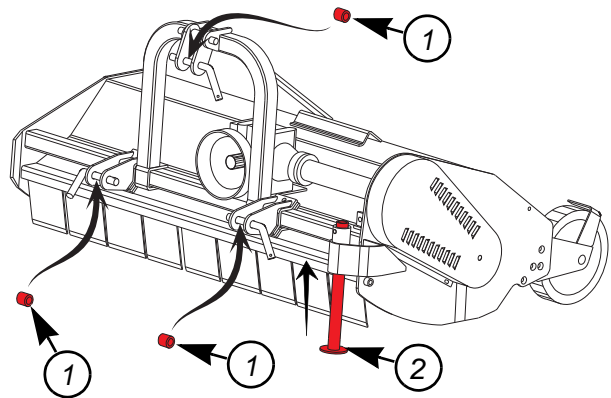

- Secure with lynch pins.
- Attach top link.
- Lock the upper hitch attachment using lynch pin.
- Lift the machine using the tractor's lift linkage.
- Fold parking stand (2) upwards and lock it in place.

**VKD**

- Lower the tractor three-point linkage.
- Place the lower links as close as possible under the hitch pins.



(a): Category 1 linkage.  
(b): Category 2 linkage.

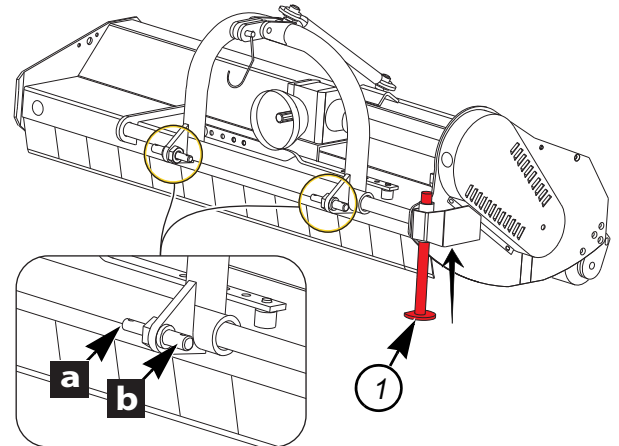

- Attach the lower links to the hitch pins.
- Secure with lynch pins.
- Attach top link.
- Lock the upper hitch attachment using lynch pin.
- Lift the machine using the tractor's lift linkage.
- Fold parking stand (1) upwards and lock it in place.

## 6.1.5 Primary PTO shaft



**Make sure that the PTO shaft is correctly adjusted, to avoid premature wear and tear.**

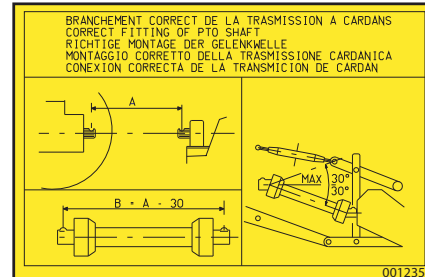

The direction of rotation is shown on a decal.

The tractor PTO stub must rotate at a speed of  $540 \text{ min}^{-1}$ .



- Separate the two half PTO shafts and connect them to the machine's input shaft and to the tractor PTO stub.
- Check the length of the PTO shaft:
  - When the PTO shaft is in its maximum overlap position (retracted), tubes should not butt against the yokes. As a safety measure, a clearance ( $L$ ) of at least 25 mm (1") must be maintained.
  - When the PTO shaft is in its maximum extended position, the tube overlap must be more than 250 mm (10").

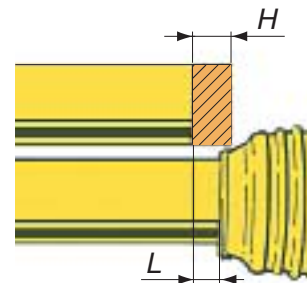

If this is not the case:

- Mark length ( $H$ ) to cut when the transmission is the maximum overlap position.
- Shorten the guard tubes and the transmission tubes by the same length.
- Bevel and clean the tubes.
- Grease the inside of the outer tube.

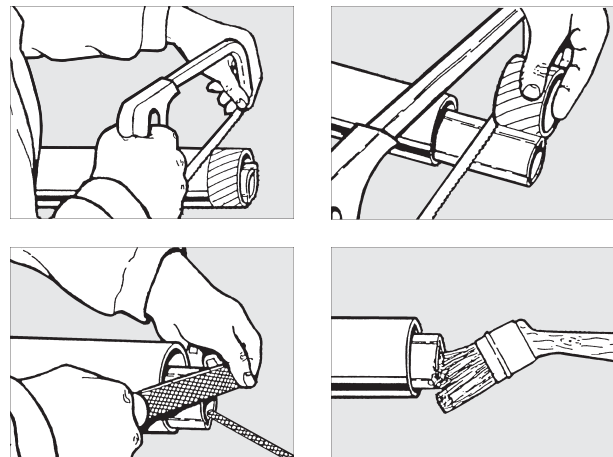

Never operate the PTO shaft at an angle X exceeding 30°.

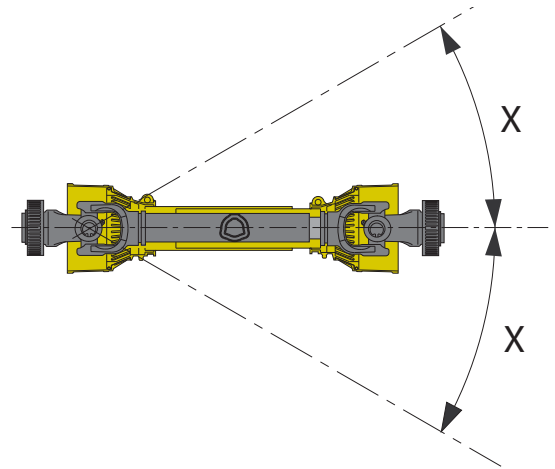

To avoid serious accidents, the PTO drive shaft guards must be properly in place and fixed with the chains provided.

On machine side, attach PTO shaft guard chain to the gear box guard fastener ((1)).

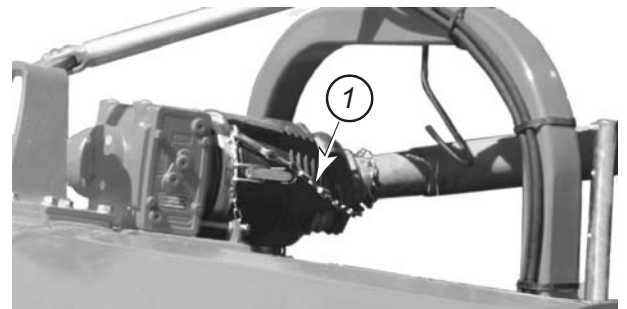

Immediately replace any worn or damaged guard.

### 6.1.6 Adjusting the machine

#### ■ Lateral adjustment of the lower links.

- Balance the play on either sides of the lift linkage and lock lower link stabilizers.

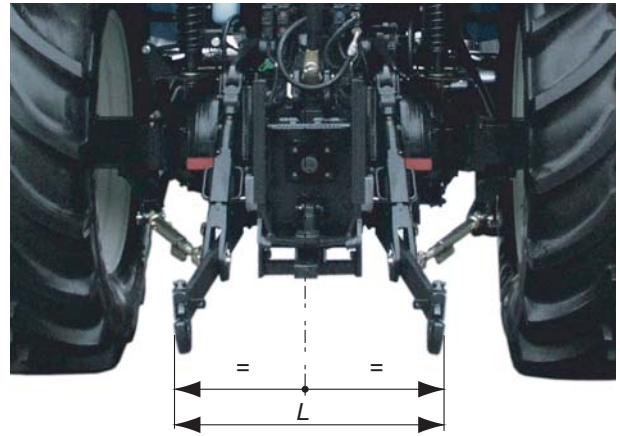

#### ■ Length of the top link

- Adjust the length of the top link in order to set the swinging yoke (1) at an angle of  $X=45^\circ$  when the machine is in the working position.

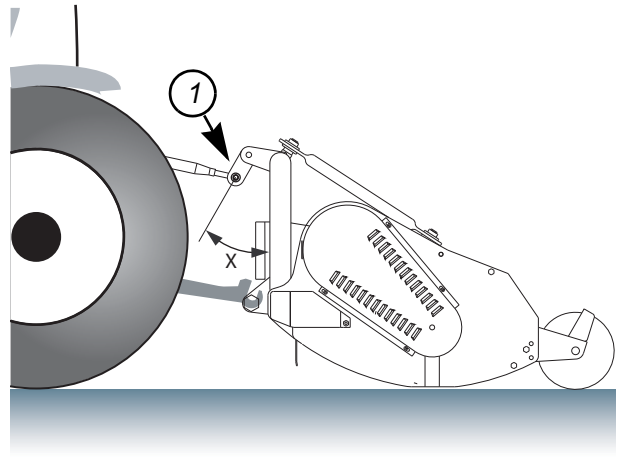



## 6.1.7 Uncoupling the machine



**Park the machine on an even fairly level ground.**



*When optional equipment is used, follow specific procedures mentioned in the related section:*

*- Hydraulic offset.*

### ■ From the working position:

- Lower and lock parking stand (1).
- Lower the tractor three-point linkage to rest the machine on the ground.
- Uncouple and place PTO shaft in support (2).
- Detach the top link from the machine end.
- Release the lower links.
- Lower the tractor three-point linkage.

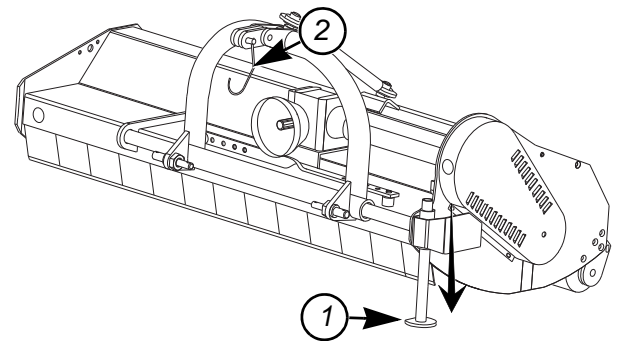

**The machine is uncoupled.**

## 6.1.8 Handling

When lifting this equipment, use appropriate lift straps, chains or any other equipment, in perfect working order, complying with safety standards in force for this type of equipment, and with capacities that exceed the total weight of the unit, as listed in this manual:

VK:

- VK 95: **290 kg (639 lb).**
- VK 115: **330 kg (728 lb).**
- VK 135: **365 kg (805 lb).**
- VK 155: **400 kg (882 lb).**



VKD:

- VKD 155: **510 kg (1124 lb).**
- VKD 170: **560 kg (1235 lb).**
- VKD 190: **600 kg (1323 lb).**
- VKD 210: **640 kg (1411 lb).**
- VKD 230: **715 kg (1576 lb).**

The location of lifting points is indicated by a pictorial.



Use lifting points (1).

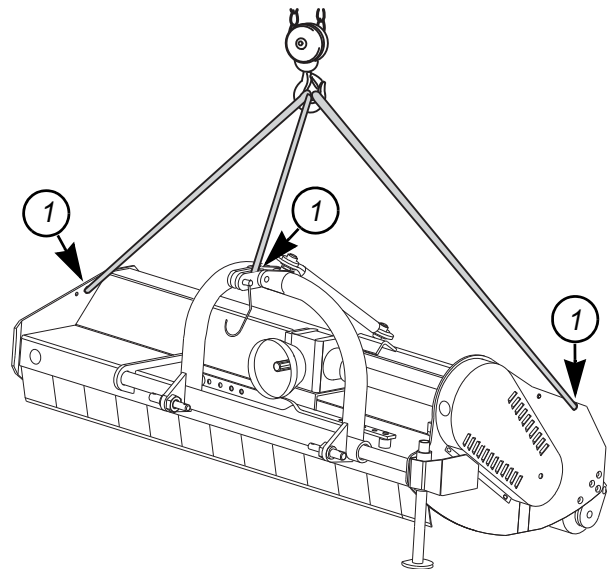

---

## 7. Instructions for transport

---



**Before placing the machine into transport position:**

- Wait until the rotating parts have come to a complete stop.
- Check that nobody is within the machine pivoting area.
- If there is someone, make sure the person moves away.

---

### 7.1 Putting the machine into transport position

---

From the working position:

- Lift the machine with the tractor's three point linkage.



*When optional equipment is used, follow specific procedures mentioned in the related section:*

- Hydraulic offset.
- Semi-pivoting wheels (VKD).

**The machine is in transport position.**



**Never engage the tractor PTO drive when the machine is in transport position.**

---

### 7.2 Conformity with the road regulations

---



**Before driving the machine on public roads, ensure that the machine complies with current highway code regulations.**

- Check that the light boards are clean and that the lighting equipment functions before transporting the machine on public roads.

---

## 8. Instructions for work

---



---

Before placing the machine in working position:

- Check that nobody is within the machine pivoting area.
  - If there is someone, make sure the person moves away.
- 

---

### 8.1 Putting the machine into work position

---

From the transport position:

- Lower the tractor's lift linkage until the rear support unit touches the ground.



---

*When optional equipment is used, follow specific procedures mentioned in the related section:*

- *Semi-pivoting wheels.*
- 

**The machine is in working position.**

---

---

## 8.2 Adjustments in working position

---

### 8.2.1 Working height

*When optional equipment is used, follow specific procedures mentioned in the related section:*



- Support wheels:
  - Iron (VK).
  - Tyres (VKD).
- Roller.
- Skid.

The working height is set by the position of the rear support unit.



**The cutting tools must never touch the ground.**

---

### 8.2.2 Height of the tractor's lift linkage

- Lower the 3 point lift of the tractor until the rear support element rests on the ground.
- Adjust lift linkage height to obtain a perfectly horizontal position.

**Avoid modifying the linkage height to tilt the machine frontwards.**



**When tilting the rear part of the machine downwards, there is an increased risk of material being ejected towards the operator.**

---

## 8.3 Machine use

**Before shredding:** Keep all persons and animals away from the machine danger zone. This zone is defined by a radius (R) of 10 m (33') around the working line of the machine.

If using a tractor with a cab that is not sound-proofed or pressurized, the operator must use individual protection equipment:



Ear protections, if the noise exceeds normal exposure limits.

Anti-dust mask if working in very dry conditions or when large quantities of dust are lifted.

If the machine starts vibrating oddly during work, immediately stop and check the condition of the rotor, the cutting tools and the balancing ballast. Excessive vibration can cause physical harm to the user.

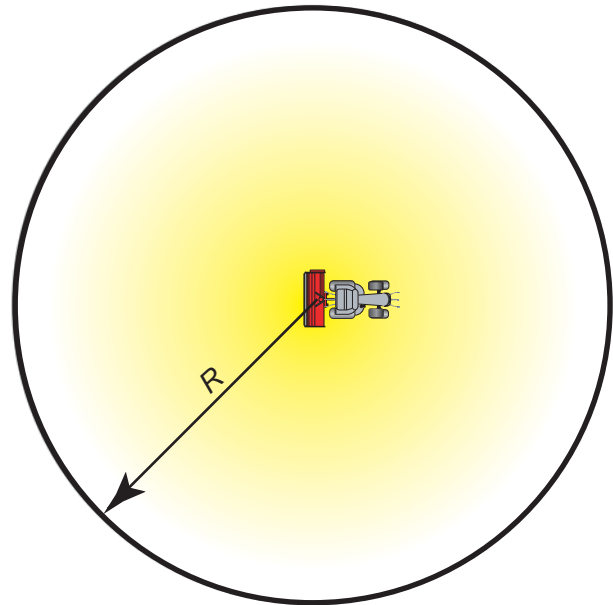

*The top link is in floating position during work to provide good ground adaptation in irregular grounds.*

### 8.3.1 Rear hood

The use of the machine hood must be only destined to maintenance operations.

Before maintaining the machine, stop the tractor motor, turn off the engine, remove ignition key and wait until all moving parts have come to a complete stop.



It is strictly forbidden to leave the hood open when the machine is operating and its parts are moving.

The misuse of the machine may cause involuntary projection of stones and other foreign objects, and consequently damages to persons, things and animals.



### 8.3.2 Drive speed

- Adapt the forward speed to the working conditions.

## 9. Optional equipment

### 9.1 Skids

Skids must be used on irregular ground to prevent cutting tool/soil contact.

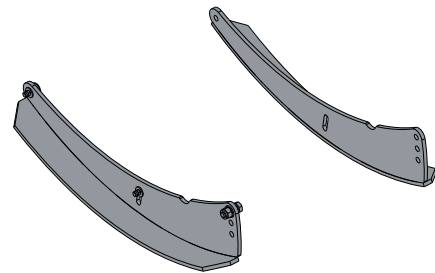

#### 9.1.1 Mounting and adjustment

Slightly lift machine off the ground using an adapted lifting device.

- Position skid in holes corresponding to the required adjustment.
- Torque bolts to (1).
- Proceed the same way on the other side.
  - Check that the 2 skids are set identically.

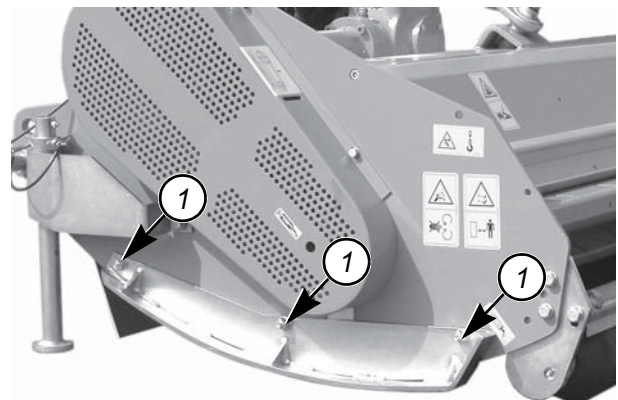



## 9.2 Support wheel

### 9.2.1 VK

The semi-pivoting wheels are recommended for shredding plant residues such as maize, rape or sunflower.

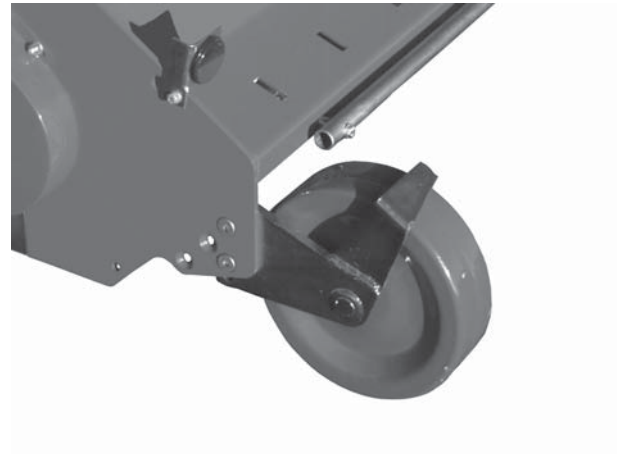

#### ■ Working height

The working height is set by the position of the rear support unit.



**The cutting tools must never touch the ground.**

- Slightly lift the machine from the ground.
- Remove bolts (1).
- Position wheel arm in hole corresponding to the required setting.
- Reinstall screws (1).
- Repeat procedure for other wheel.

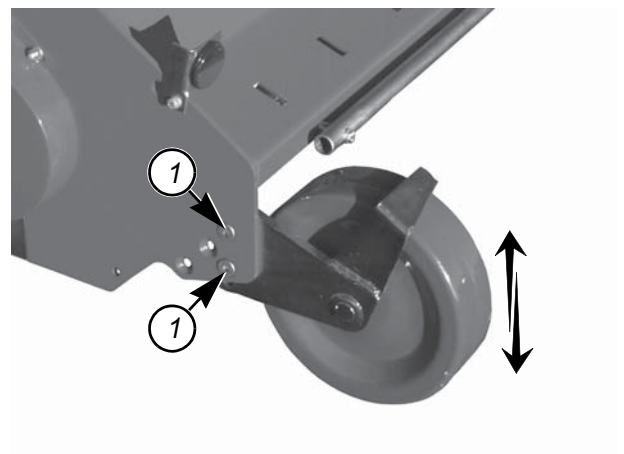

■ **Maintenance**

**Grease**

Every 8 hours:

- The wheel pins.

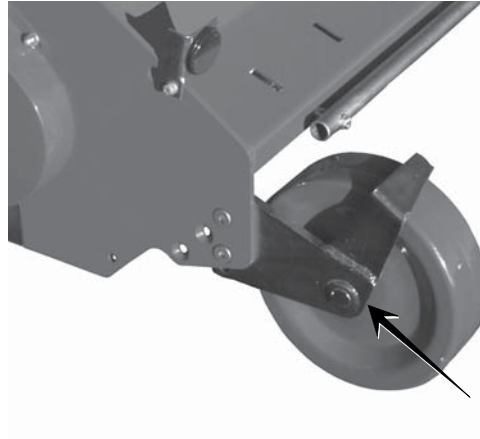

**9.2.2 VKD**

The semi-pivoting wheels are recommended for shredding plant residues such as maize, rape or sunflower.



### ■ Working height

The working height is set by the position of the rear support unit.



**The cutting tools must never touch the ground.**

- Slightly lift the machine from the ground.
- Loosen screw (1).
- Remove screw (2).
- Position wheel arm in hole corresponding to the required setting.
- Reinstall and tighten screw (2).
- Tighten screw (1).
- Repeat procedure for other wheel.

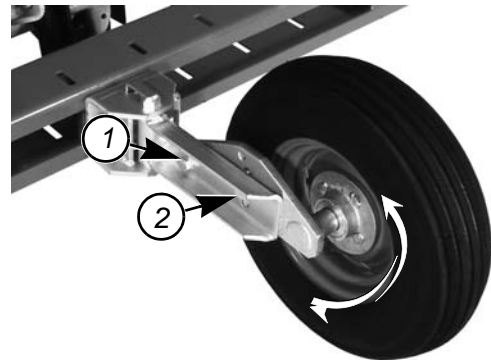

### ■ Adjusting the track

- Unscrew the 2 nuts (1).
- Place holder (2) in the required position.
- Tighten the 2 nuts (1).

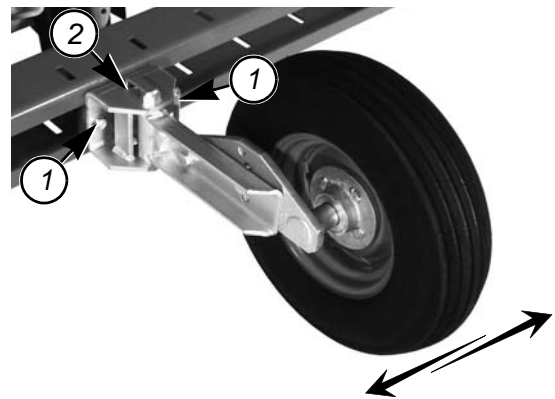

■ **Maintenance**

**Grease**

Every 4 hours:

- The wheel pins.



**Check**

Tyre pressure: 3 bar (43.5 psi).

---

## 9.3 Roller

The roller can be used for shredding set-aside land, pasture land and crop residues.

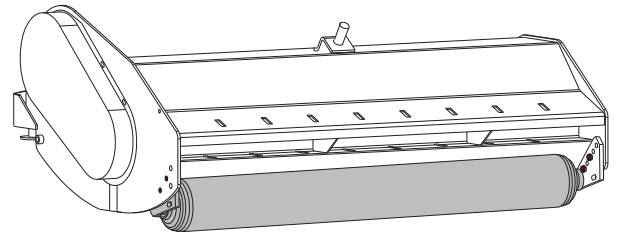

### 9.3.1 Adjustments

#### ■ Working height

The working height is set by the position of the rear support unit.



**The cutting tools must never touch the ground.**

- Slightly lift the machine from the ground.
- remove screws and nuts (1).
- Position roller in holes corresponding to the required adjustment.
- Reinstall bolts and nuts (1).
- Proceed the same way on the other side.

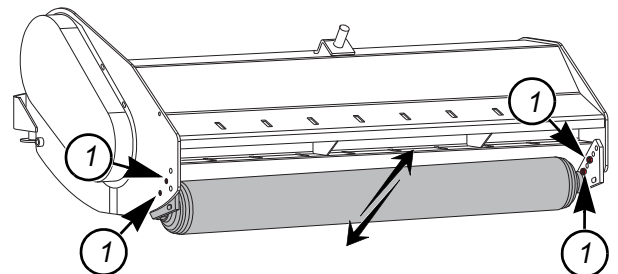

#### ■ Adjusting the scraper

According to the soil type and its adherence to the roller, it is possible to modify the position of the mud scraper (1).

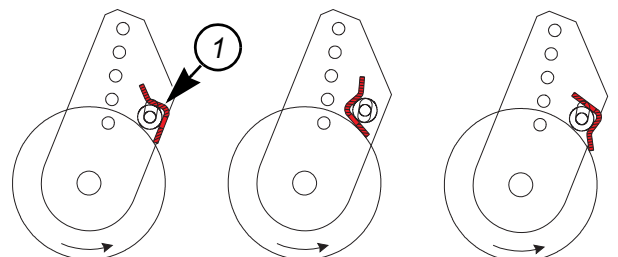

### 9.3.2 Machine use



When using collecting tines with the roller, the position of the roller must be modified.

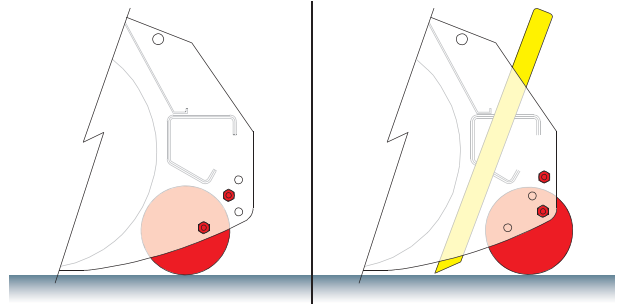

### 9.3.3 Maintenance

#### ■ Grease

Every 4 hours:

- Roller bearing housings.

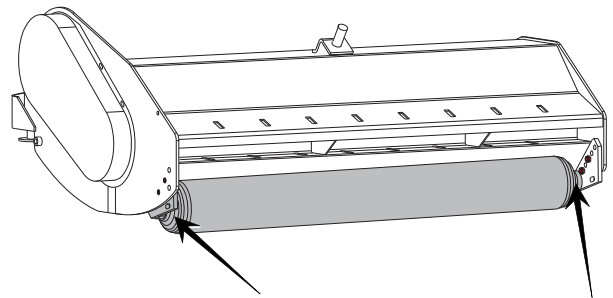

## 9.4 Collecting tines

This equipment allows raking the ground in order to collect residues sticking to the ground.

### 9.4.1 Height adjustment

- Remove R-clip (1).
- Adjust to the required working height.
- Reinstall R-clip (1).

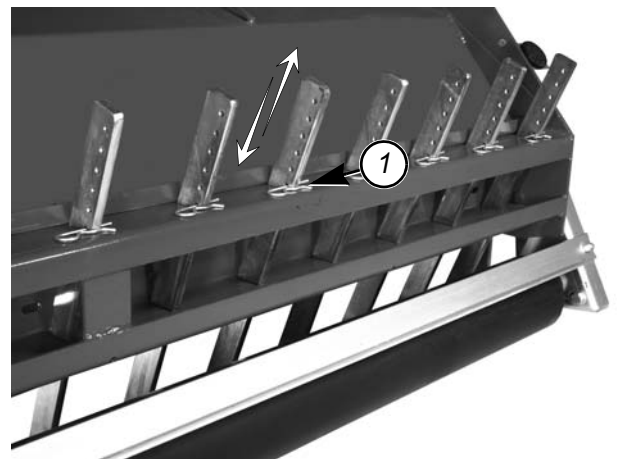

### 9.4.2 Machine use



**When using collecting tines with the roller, the position of the roller must be modified.**

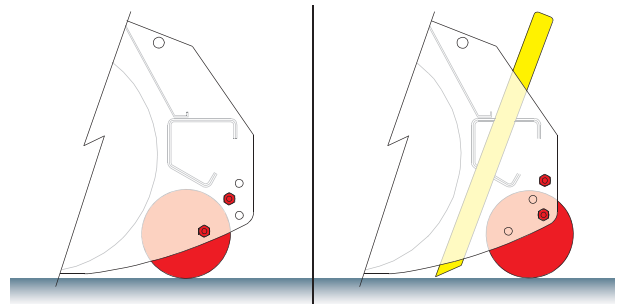

## 9.5 Lighting and signalling

The rear safety device comprises:

- 2 signalling panels (1).

The front safety device comprises:

- 2 reflective self-adhesives (2)

The side device comprises:

- 2 signalling panels (3).
- 2 amber reflectors (4).

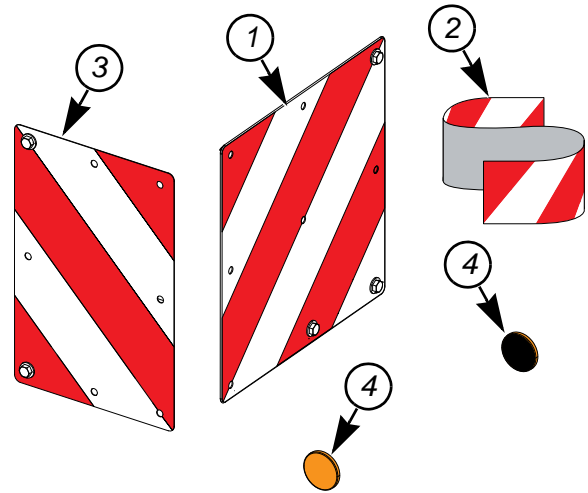



## 9.6 Hydraulic offset

VKD 155

The hydraulic offset can be used to offset the machine up to 360 mm (1'02").

VKD 170-190-210-230

The hydraulic offset can be used to offset the machine up to 450 mm (1'06").

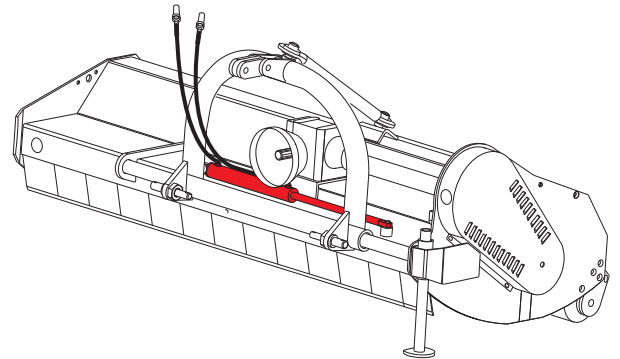

### 9.6.1 Hydraulic connection

- Connect hydraulic hoses (a) and (b) to a double acting outlet.

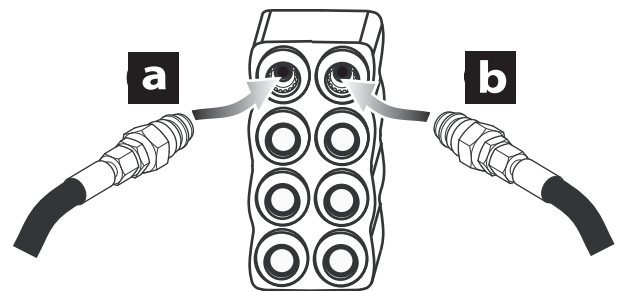

### 9.6.2 Putting the machine into transport position

From the working position:

- Lift the machine with the tractor's three point linkage.
- Activate offset cylinder to put the machine in line with the tractor

### 9.6.3 Machine use

- Slightly lift the machine from the ground.
- Operate offset cylinder to move machine sideways or to center it with regards to the tractor.

## 9.7 Mow-around disk (VKD)

This equipment allows mowing around obstacles without modifying the tractor's trajectory.

### 9.7.1 Identification

- **View of the equipment**

Machine without a hydraulic system

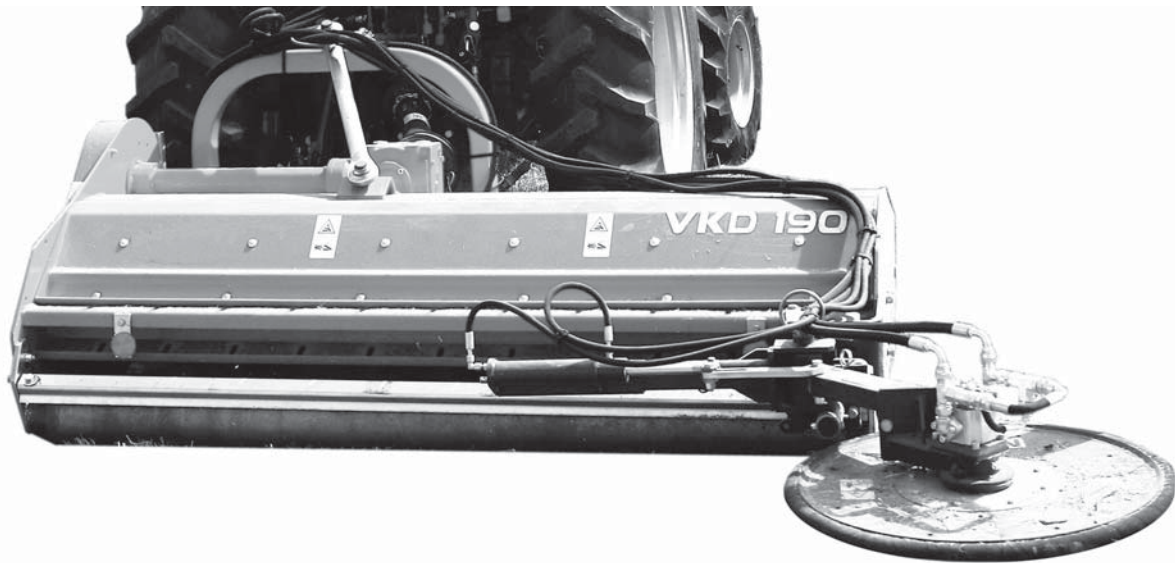

Machine with hydraulic power unit

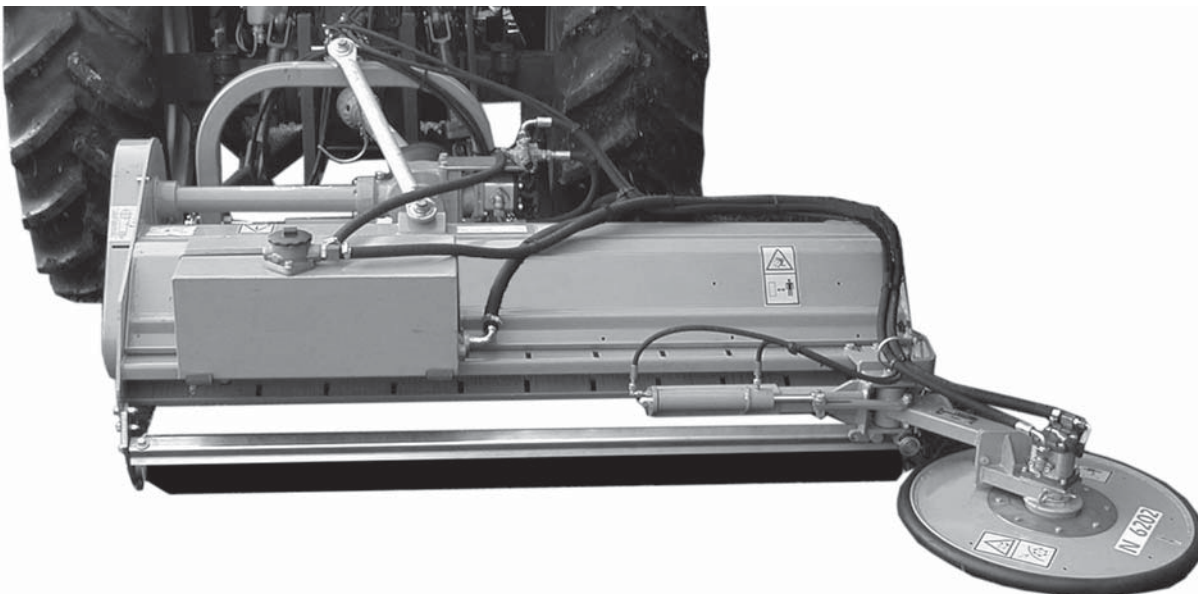

■ **Model identification plate**

Please write below the type and serial number of the machine. This information is to be given to your NOBILI dealer for all parts order or warranty claim.

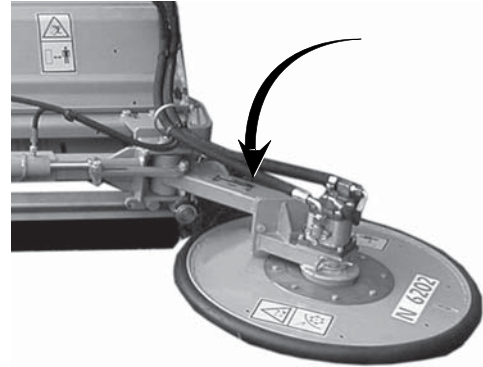

**Type: N6202**  
**Serial no.:**

				COSTRUZIONI MECCANICHE PER L'AGRICOLTURA <small>s.p.a. - 40062 MOLINELLA (BO) ITALIA -</small>			
<b>TRINCE BROYEURS TRITURATOR MULCHER</b>		BLASIA 220 (ISO 220)	SUPERTRACTOR UNIVERSAL 15W/40	MU / EP2			
Mod. : _____							
Num. : _____		Data : _____		<b>LUBRIFICANTI CONSIGLIATI</b> <small>LUBRIC. ACONSEJADOS - RECOMMENDED LUBRICANTS          EMPFOHLENE OELFETTET - LUBRIFIANTS CONSEILLES</small>			
Massa Kg : _____							

**9.7.2 Safety instructions**

■ **Location of safety decals**

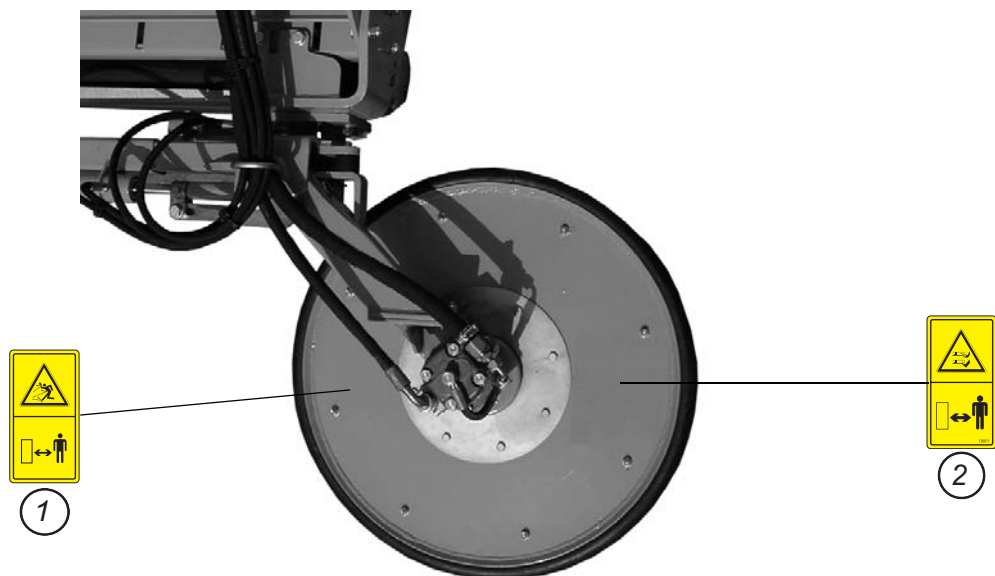

■ **Description of safety decals**

**Projections (1)**

Stones and other debris projected by the moving parts can travel a long distance. The guard plates/covers must always be in position and in good condition. Always stay at a safe distance from the machine.



**Rotating cutting tools (2)**

Keep away from the machine tools all the time the engine is running, the PTO drive engaged and the moving parts have not come to a complete stop.



### 9.7.3 Machine specifications

■ **Technical specifications**

Machine without a hydraulic system:

<b>N6202</b>	
Min. power requirement	4.4 kW (6 hp)
Working width	620 mm (2'0.41")
Drive	Drive per tractor hydraulics
Rotor speed	2500 min <sup>-1</sup>
Knives peripheral speed	81 m/s
Number of knives	2
Weight	140 Kg (310 lb)

Machine with hydraulic power unit:

<b>N6202</b>	
Min. power requirement	4.4 kW (6 hp)
Working width	620 mm (2'0.41")
Drive	Auxiliary hydraulic unit
Hydraulic tank capacity	35 L (9.25 US gal)
Rotor speed	2500 min <sup>-1</sup>
Knives peripheral speed	81 m/s
Number of knives	2
Weight	140 Kg (310 lb)

**Dimensions:**

**N6202**

**A** 796 mm (2'7.3")

**B** 620 mm (2'0.4")

**C** 554 mm (1'9.8")

**D** 604 mm (1'11.7")

**E** 301 mm (11.8")

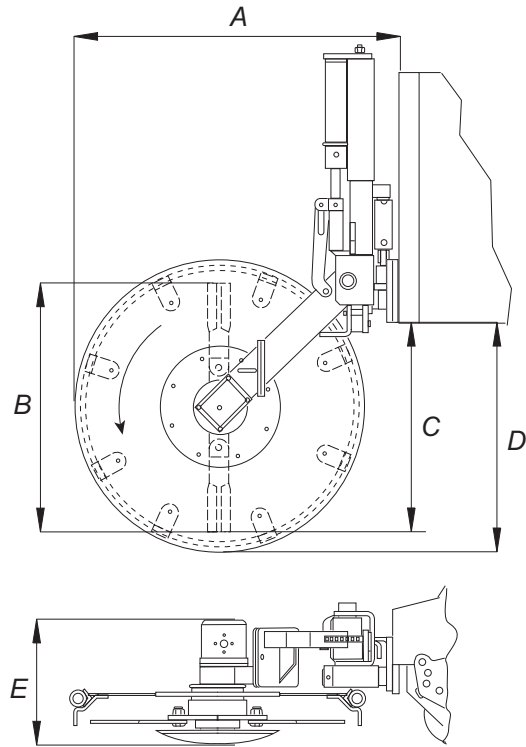

## ■ Sound levels

Sound levels have been measured in accordance with the measuring methods as defined in:

### **EN ISO4254-1: 2009**

«Agricultural machines - Self-propelled, mounted, semi-mounted and trailed - Common safety recommendations»

Weighted equivalent continuous acoustic pressure level at the driver's seat (closed cabin) **L(A)eq** according to standard **UNI EN ISO 11201**

- VKD155-4170-190-210 + N6202: **77.6 dB(A)**

Measured weighed volume level **Lw(A)** according to standard **UNI EN ISO 3744: 1997** for machines that exceed a pressure of 80dB(A) in the driver's post:

- VKD155-4170-190-210 + N6202: **81.7 dB(A)**



**Wear ear protectors!**



## 9.7.4 Putting into service

### ■ Coupling and uncoupling

#### Description of coupling elements

Machine without a hydraulic system:

- 1 single acting outlet with free return to the tank.
- 1 double acting hydraulic outlet.

Machine with hydraulic power unit:

- 1 double acting hydraulic outlet.

■ **Hydraulic connections**



**Before connecting hoses to the tractor hydraulics, ensure that tractor and machine circuits are not under pressure.**

**Before disconnecting a hose, depressurize the hydraulic circuit.**



**Clean the couplers before each connection.**

Machine without a hydraulic system:

- Connect hydraulic hoses (a) and (b) to a double acting outlet.

- Connect hydraulic hose (c) to a single acting outlet. Hose (c) feeds the hydraulic motor driving the knives.

- Connect hydraulic hose d to the tractor free return. Hose (d) is used as free return for the hydraulic motor driving the knives.

If the tractor is not equipped with a "FLAT FACE" coupler, install coupler supplied with the machine to connect the hose (b) to the tractor return to the tank.

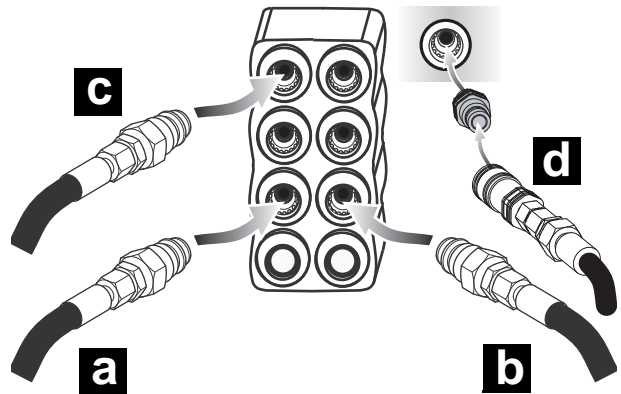

Machine with hydraulic power unit:

- Connect hydraulic hoses (a) and (b) to a double acting outlet.

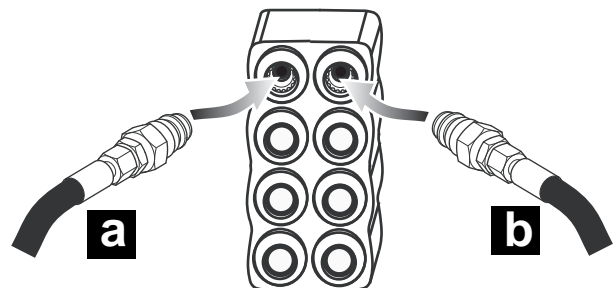



### 9.7.5 Instructions for transport

Before placing the machine into transport position:



- Wait until the rotating parts have come to a complete stop.
- Check that nobody is within the machine pivoting area.
- If there is someone, make sure the person moves away.

#### ■ Putting the machine into transport position

From the working position:

- Activate double acting valve to place the mow-around disk behind the machine.

### 9.7.6 Instructions for work

Before placing the machine in working position:



- Check that nobody is within the machine pivoting area.
- If there is someone, make sure the person moves away.

#### ■ Putting the machine into work position

From the transport position:

- Activate double acting valve to place the mow-around disk in working position.

#### ■ Adjustments in working position

Disengagement effort

- Tighten nut (1) to increase the release effort.
- Loosen nut (1) to reduce the release effort.

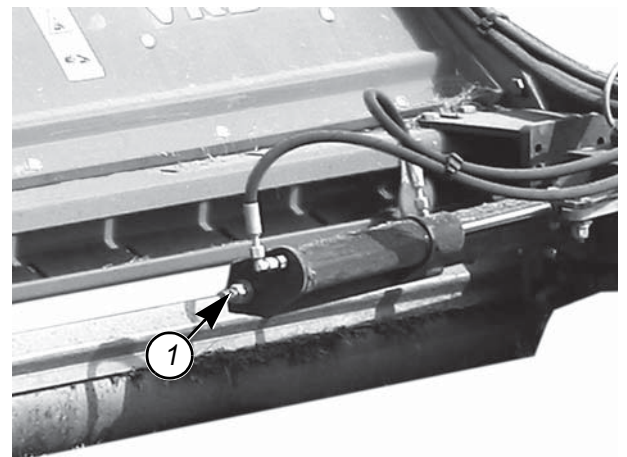

### 9.7.7 Maintenance and storage

■ Frequency chart

	Daily	Every 8 hours	Every 100 hours
<b>Greasing</b>			
- Grease all greasing points		✓	
<b>Maintenance</b>			
- Check the oil level in the reservoir .	✓		
- Oil filter replacement			✓

■ **Lubrication**

**Grease**



*Lubricate with multi-purpose lithium grease.  
Clean grease nipples before greasing.*

The pictorials show the points to be greased ((1)).

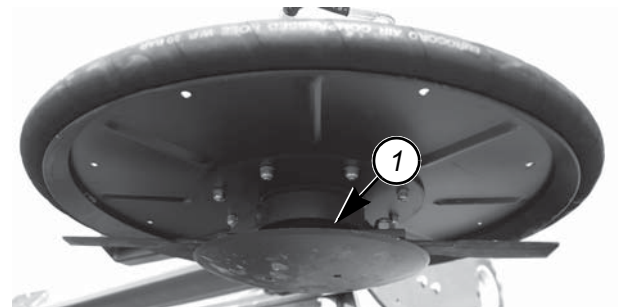
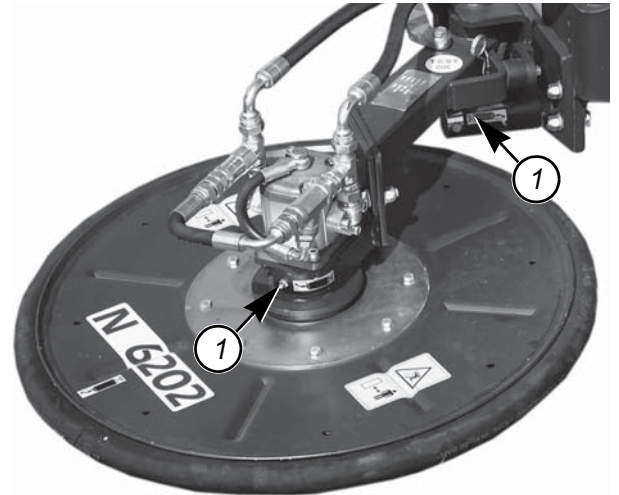

■ **Maintenance**

**Check the oil level in the reservoir .**

Machine with hydraulic power unit:



*The oil reservoir contains 35 L (9.25 US gal) of a mineral base oil with viscosity grade conform with ISO 46 standard category HM.*

- Remove plug (1).
- Check oil level using a slide.
- Measure A must be between 50 mm (1.97") and 80 mm (3.15").
- Top up if necessary.
- Reinstall plug (1).

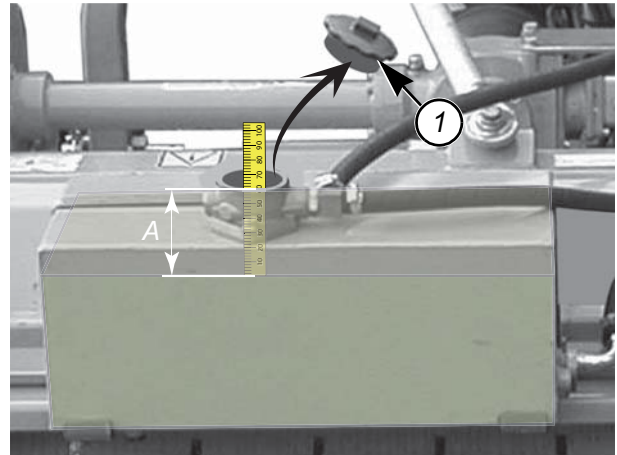

**Oil filter replacement**

Machine with hydraulic power unit:

- Remove plug (1).
- Replace oil filter.
- Reinstall plug (1).

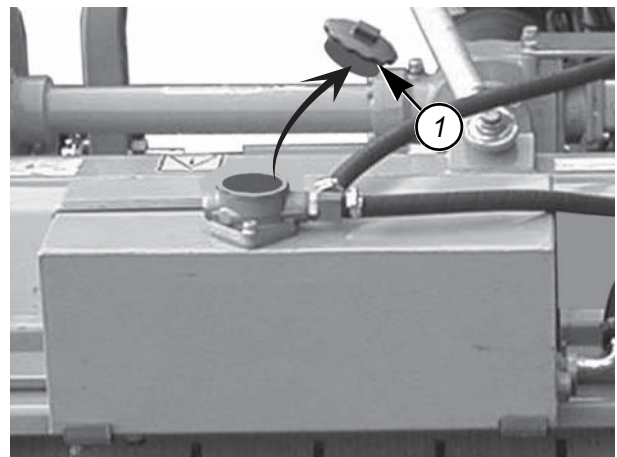

**Check cutting tools and their fixing elements**

Cutting tools:

Check cutting tools before each use in order to:

- ensure shredding quality.
- ensure safety in use.
- avoid risk of damaging the fixing elements.

Replace cutting tools in the following cases:

- Damaged cutting tools:
  - Very uneven ground can cause the knives to crack or warp.
- Important wear.

Knives

- The cutting tool length L1 must exceed 30 mm (1.18").
- Ovalisation of the mounting hole L2 must not exceed 17.5 mm (0.69").

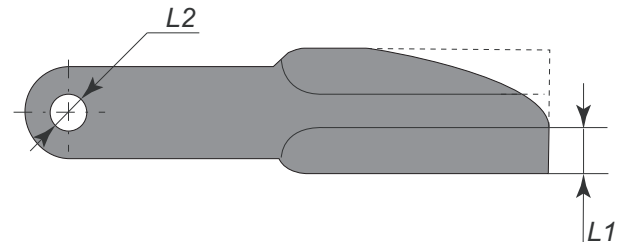

Securing elements

Check the condition of the securing elements regularly and also the torque of the knife-fixing bolt. Torque: 13.5 daN m (100 lbf ft).

Check the securing elements:

- After hitting an obstacle.
- When knives are replaced.
- At the start of each season.

The fixing bolts should be changed in the following cases:

- When there is visible distortion.
- When the thread is damaged or worn.
- When a groove (H) of over 2 mm (0.08") has developed.

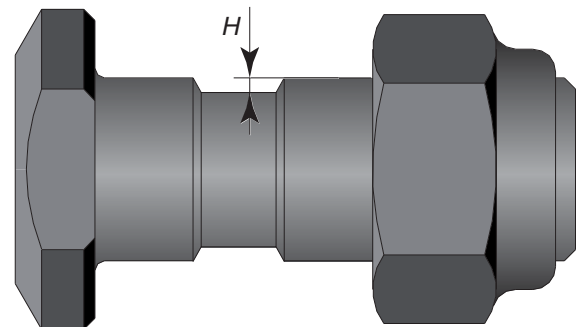

## 10. Maintenance and storage



Before adjusting, maintaining or repairing the machine, turn off ignition key and wait until all moving parts have come to a complete stop.



### 10.1 Frequency chart



Maintenance intervals are indicated for normal conditions of use.

	After the first 3 hours of use	Every 4 hours	Every 8 hours	Every 30 hours	Every 250 hours or at the end of the season
<b>Grease:</b>					
- Cardan cross joints - PTO shaft tubes - The PTO shaft guiding bushes - Hitch sliding tubes (VKD)			✓		
- Rotor bearings		✓			
<b>Draining:</b>					

	After the first 3 hours of use	Every 4 hours	Every 8 hours	Every 30 hours	Every 250 hours or at the end of the season
- Central gearbox				✓	✓
<b>Maintenance</b>					
- Belt tension	✓		✓		

## 10.2 Cleaning the machine

- Regularly clean the rotor and the machine inner panels.

## 10.3 Lubrication

The pictorials show the points to be greased.

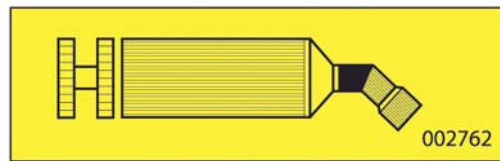

- Clean grease nipples before greasing.



Lubricate with EP/2 multi-purpose lithium grease.

### 10.3.1 PTO shaft

#### ■ Primary PTO shaft

- Every 8 hours:
  - universal joints (1).
  - transmission tube (2).
  - Guide rings (3).

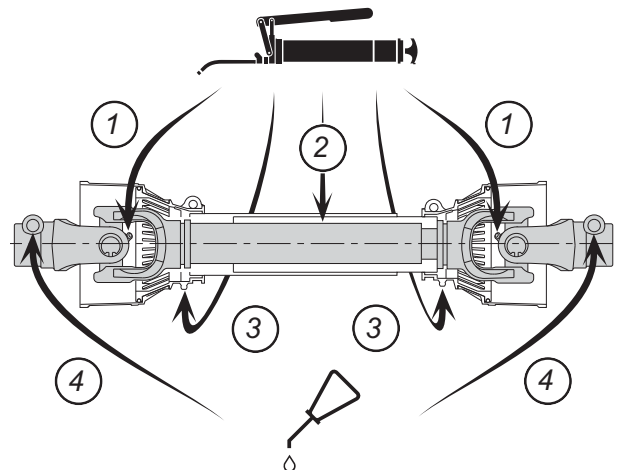



### 10.3.2 Grease

- Hitch sliding tubes (1)

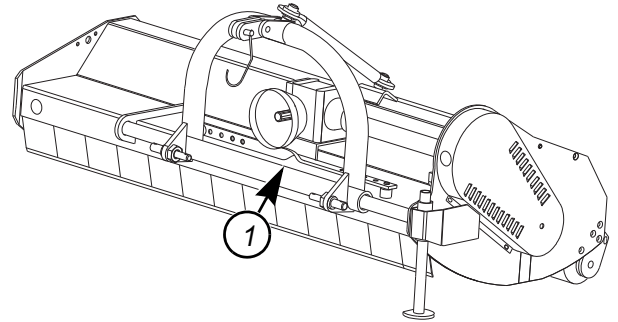

Grease rotor bearings (1).

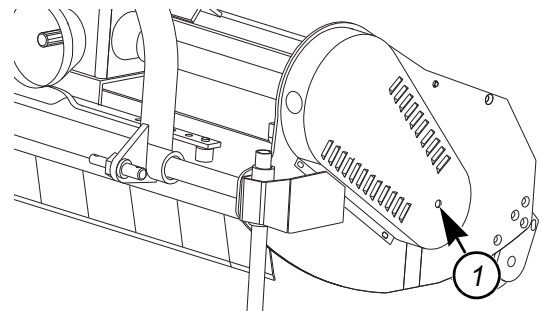

### 10.3.3 Oil change

#### ■ Central gearbox



Before draining oil, operate the machine for a few minutes so that the oil warms up.



Lubricate with SAE 90 EP (ISO220) gear oil.



- VK 95-115: 0.9 L (0.294 US gal).
- VK 135-155: 1.0 L (0.27 US gal).
- VKD 155-170: 1.3 L (0.34 US gal).
- VKD 190: 1.4 L (0.37 US gal).
- VKD 210: 1.5 L (0.40 US gal).
- VKD 230: 1.6 L (0.42 US gal).

- Park the machine on an even fairly level ground.
- Remove filler plug (1).
- Place a container of sufficient capacity under drain plug.
- Remove drain plug (2).
- Allow oil to drain completely.
- Wait for dripping to stop.
- Clean and reinstall drain plug (2) and its washer. Replace if necessary.
- Pour the correct oil quantity and quality through the opening of the filler plug.
- Reinstall filler plug (1).

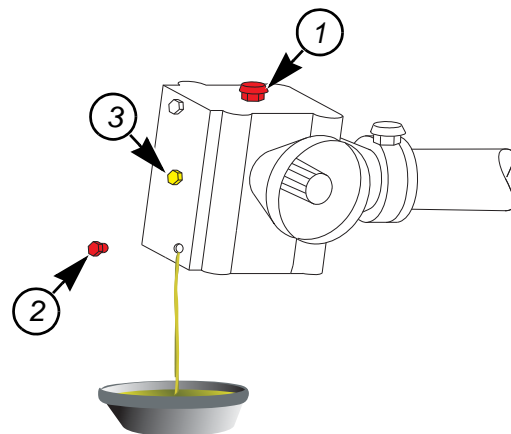

- Remove level plug (3):
  - The oil level must reach lower part of level plug hole. Top up if necessary.
- Reinstall level plug (3).

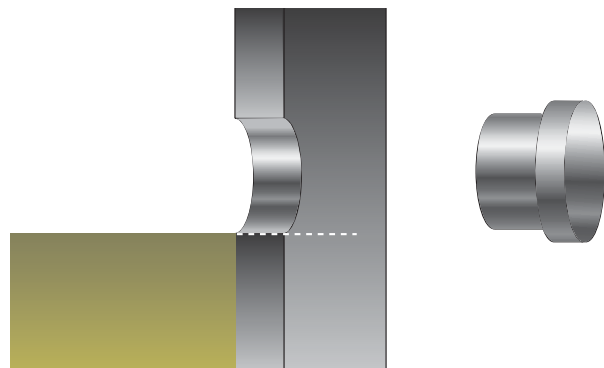

---

## 10.4 Maintenance

---

### 10.4.1 Checking the oil levels

---

 Place the machine on level ground.

---

Check central gearbox oil level:

- Remove level plug (1).

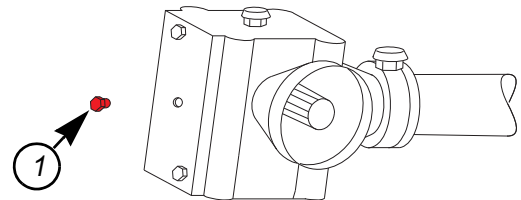

The oil level must reach lower part of level plug hole.

- Reinstall level plug (1).

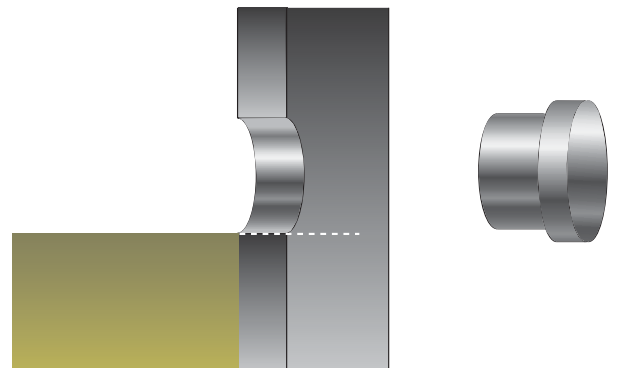

## 10.4.2 Check cutting tools and their fixing elements

### ■ Cutting tools:

Universal knives Type 01 (1)

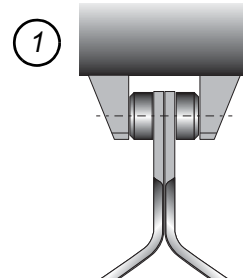

Hammer Type 06 (5)

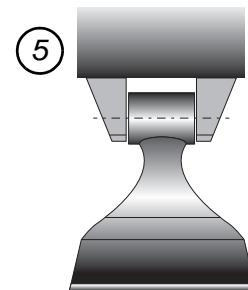

Check cutting tools before each use in order to:

- ensure shredding quality.
- ensure safety in use.
- avoid risk of damaging the fixing elements.

Replace cutting tools in the following cases:

- Damaged cutting tools:
  - Very uneven ground can cause the knives to crack or warp.
- Important wear.

### Universal knives

- The length L1 of the universal knives must exceed 90 mm (3.54").
- Ovalisation of the mounting hole L2 must not exceed 18 mm (0.71").

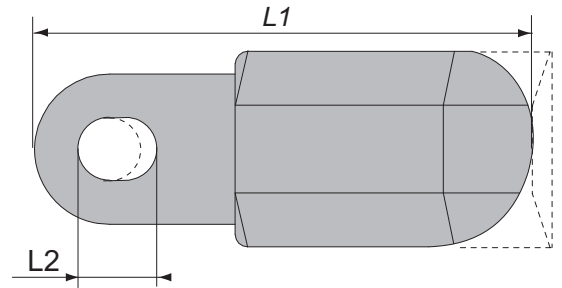

### Hammer knives

- The cutting tool length L1 must exceed 90 mm (3.54").
- Ovalisation of the mounting hole L2 must not exceed 18 mm (0.71").

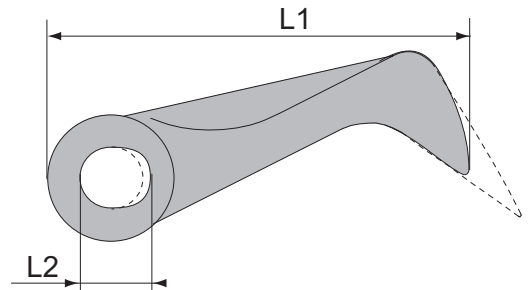

### ■ Securing elements

Check the condition of the securing elements regularly and also the torque of the knife-fixing bolt. Torque: 10.5 daN m (77.4 lbf ft).

Check the securing elements:

- After hitting an obstacle.
- When knives are replaced.
- At the start of each season.

The fixing bolts should be changed in the following cases:

- When there is visible distortion.
- When the thread is damaged or worn.
- When a groove (H) of over 2 mm (0.08") has developed.

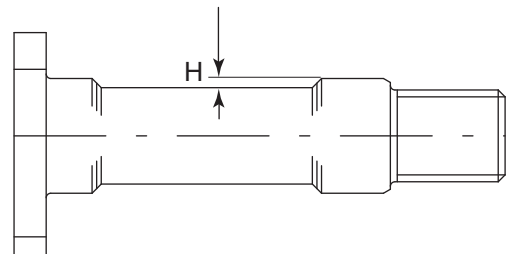

## ■ Replacing knives and pallet knives



**Immediately replace worn or damaged parts with original manufacturer parts.**



**Replace self-locking nuts after each removal operation:**

- **Torque: 10.5 daN m (77.4 lbf ft).**

From the transport position:

- Uncouple PTO shaft on machine side.

### **Partial replacement:**

- Lift the machine using the tractor's lift linkage.
- Prop up frame using trestles.
- Replace damaged or worn knives.
- Replace the knives that are diametrically opposite to maintain the existing balance.
- Check that there is still 1 to 2 mm (0.04" - 0.08") play between the pair of knives and the supports.

### **In parking position:**

- Slightly lift machine off the ground using an adapted lifting device.
- Tip the machine forward.
- Lower the lifting device until the attachment yokes touch the ground.

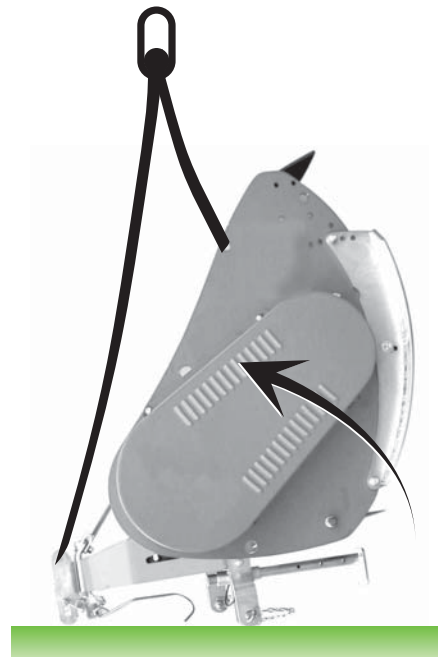



**Keep the slings under tension.**

- Weigh cutting tools.
- Pair up equally weighted cutting tools so that they can be placed diametrically opposite.



*Put the lighter pairs in the center of the rotor and the heavier pairs to the edges.*

- Fit the knives according to the direction of travel of the machine.
- Check that there is still 1 to 2 mm (0.04" - 0.08") play between the pair of knives and the supports.

**Checking the balance:**

- Couple PTO shaft on machine side.
- Slightly lift the machine from the ground.
- Start the PTO drive and increase speed progressively up to a steady speed of 540 min<sup>-1</sup>.
- When mounted correctly, the rotor must rotate without causing the machine to vibrate.

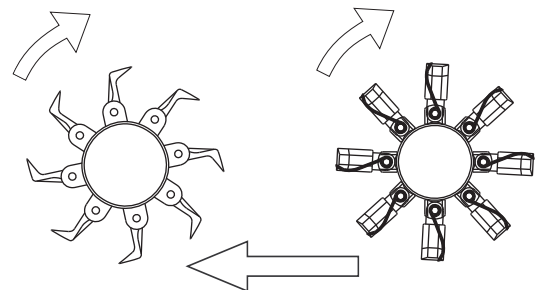
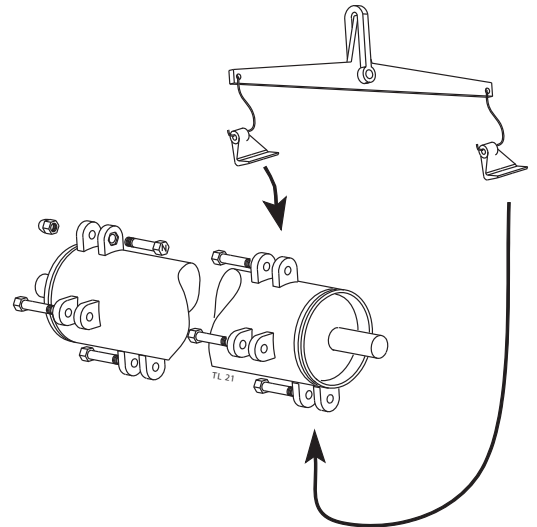

### 10.4.3 Belt tension



**Check belt tension:**  
After the first 3 hours of use.  
Every 8 hours.

- **Checking the tension:**  
Through the belt guard slot:

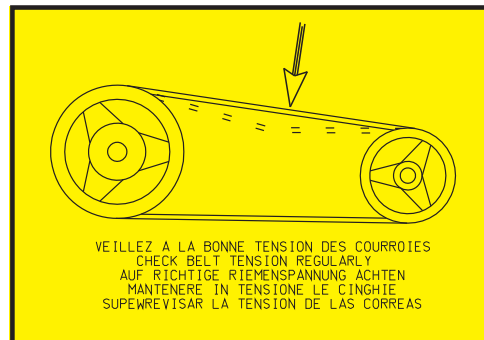

VK:

- Apply a force of 25 N (5.62 lbf) on the belt: the belt should not deflect more than  $H = 5.5 \text{ mm}$  (0.22").

VKD:

- Apply a force of 25 N (5.62 lbf) on the belt: the belt should not deflect more than  $H = 6.5 \text{ mm}$  (0.26").

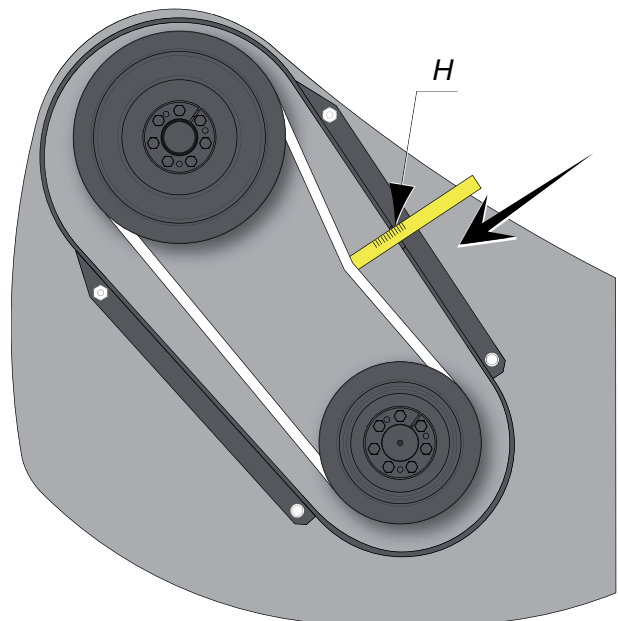



■ **Adjusting the tension:**



Replace belts, if proper tension can no longer be obtained.



Always replace the complete belt set if one of them is damaged.

Remove side gearbox (1):

- Loosen nuts (1).
- Remove side gearbox (2).

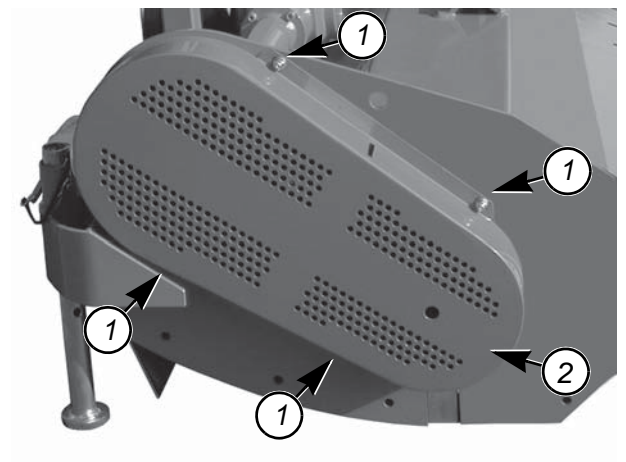

Retention V-belts:

- Loosen screws (1).
- Loosen counternuts (2).
- Turn the adjustment screws (3) and nuts (4) equally until reaching the optimum tension.

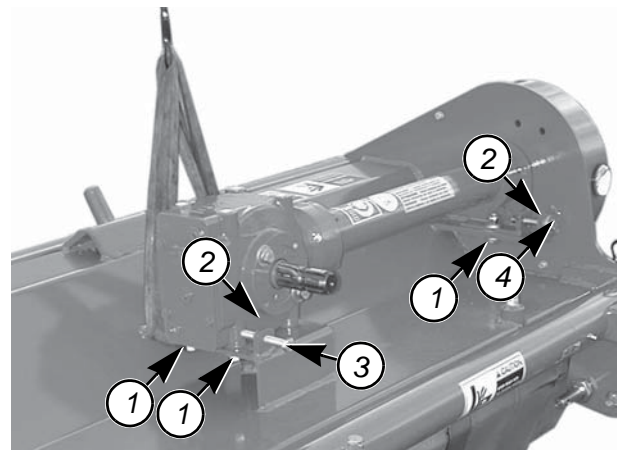

By adjusting (3) and (4) equally, the central transmission shaft is kept parallel to the rotor.

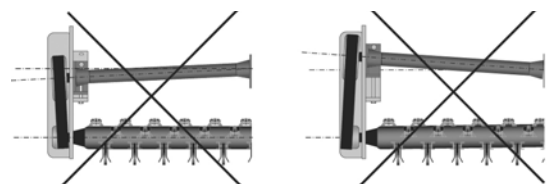

- Tighten screws (1).
- Tighten counternuts (2).

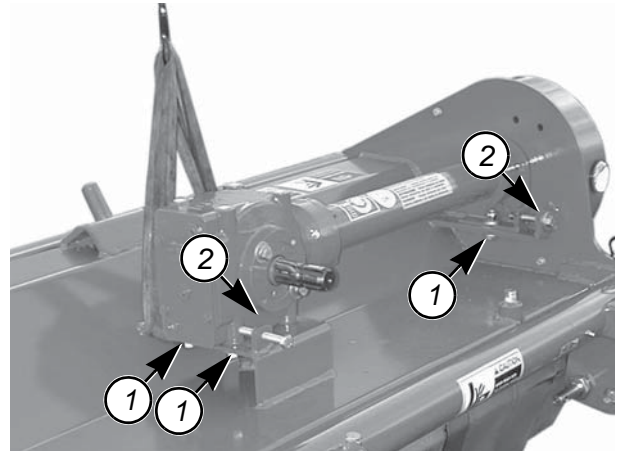

- Using a ruler, check that pulleys are in line (1).
- Repeat procedure until perfect pulley alignment is obtained.



- Reinstall side gearbox (1).
- Refit nuts (2).
- Torque: 5 daNm (37 lbf ft).

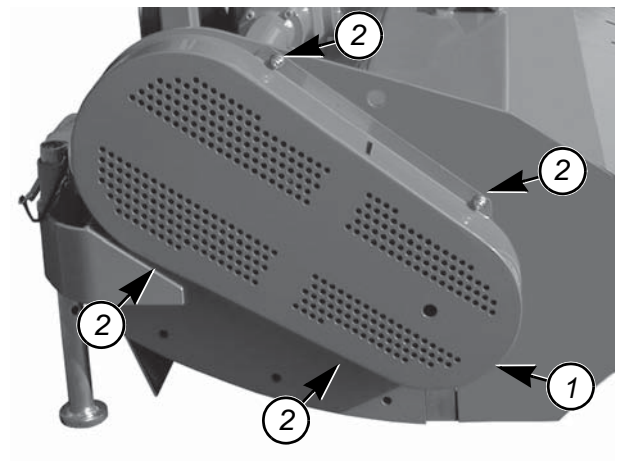

---

## 10.5 Storage

---

### 10.5.1 At the end of each season

- Clean the machine thoroughly:
  - The rotor.
  - The inner panels.
  - Rotor housings.
  - Roller housings.
- Touch up any areas of damaged paintwork.
- Lubricate all mechanical components correctly to protect them from corrosion.
- Put the machine under cover in a dry place.
- Check the condition of the securing elements regularly and also the torque of the knife-fixing bolt. Replace if necessary.
- Check that the original safety decals are in their original location, undamaged and legible.
- Drain bevel gearbox and fill with new oil.
- Slacken V-belts and check their condition.

- Grease the cylinder rods in contact with the outside.

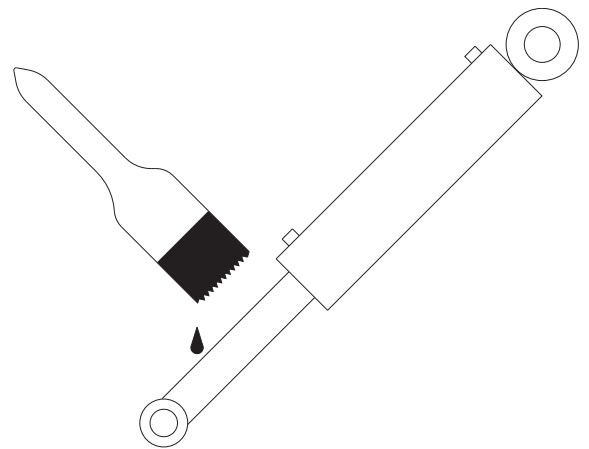

### 10.5.2 At the start of each season

- Re-read the operators' manual.
- Check that the machine is greased.
- Check all the knives and fixings, and replace if necessary.
- Check that all nuts and bolts are sufficiently tightened.
- Retension V-belts.
- Check belt guard condition and if it is firmly secured in place.
- Make sure that all protection devices are in place and in good condition.
- Wipe off grease on cylinder rods.

---

## 10.6 Machine recycling

---

In case of recycling, the machine will have to be recycled in conformity with the legislation in force in the country concerned.

Prior to proceeding with the recycling, remove all plastic or rubber parts, electric or electronic equipment.

Collect possible residual oil and give it to an appropriate processing center.

Parts only made up of plastic, aluminium, steel can be recycled if they are collected by an appropriate center.

---

## 11. Troubleshooting guide

■ Problem	■ Cause	■ Remedy
Excessive vibrations	<ul style="list-style-type: none"> <li>- Breakage or excessive wear of knives or hammer knives.</li> <li>- Knife or hammer knife jamming on the pivot point.</li> <li>- Incorrect rotor balance</li> </ul>	<p>Replace worn or damaged parts.</p> <p>Clean and grease pivot points.</p> <p>Check weight of knives and hammer knives.</p>
Poor cutting quality due to a drop in the rotor speed.	<ul style="list-style-type: none"> <li>- Insufficient belt tension.</li> <li>- Excessive belt wear.</li> </ul>	<p>Adjust tension.</p> <p>Replace belts.</p>
Belt overheating.	<ul style="list-style-type: none"> <li>- incorrect belt tension.</li> <li>- The angle gearbox axle is no longer in line with the rotor axle.</li> </ul>	<p>Check tension.</p> <p>Check alignment.</p>
Angle gearbox overheating.	<ul style="list-style-type: none"> <li>- Lack of oil.</li> <li>- No oil.</li> </ul>	<p>Top up until proper oil level is reached.</p> <p>Replace gearbox.</p>
Fast knife or hammer knife wear.	<ul style="list-style-type: none"> <li>- Working position too low, interference with the ground.</li> </ul>	<p>Adjust working height.</p>
Drive shaft oil loss on the belt side.	<ul style="list-style-type: none"> <li>- Seal wear or breakage.</li> </ul>	<p>Replace seal.</p>

■ Problem	■ Cause	■ Remedy
Distortion of roller or wheel supports.	- The roller or wheel supports have been subject to lateral forces.	Raise machine off the ground when inverting the direction of travel or steering the wheels.
Distortion of the front pivoting safety flaps.	- The machine has been lowered onto the residues to shred from the raised position (transport position).	The machine must be in working position before coming into contact with the residues to shred.
Rotor jamming during work.	- Clogging due to foreign bodies (example: wire, plastic material).	Put on gloves and remove foreign bodies with adequate tools.

## 12. Appendix

### 12.1 Calculating the load on an axle

When coupling a tool to the front and/or rear 3-point lift linkage, the maximum authorized payload must not be exceeded.



When coupling tools to the front and/or rear 3-point lift linkages, the maximum load on tractor's tires must not be exceeded

The load on the tractor front axle must always represent 20 % of the tractor unladen weight.

Prior to use, check that these conditions are satisfied by making this calculation or by weighing the tractor-machine unit

- Define the total weight, axle loads, tyre capacity and minimum additional mass:

The following values are required for the calculation:

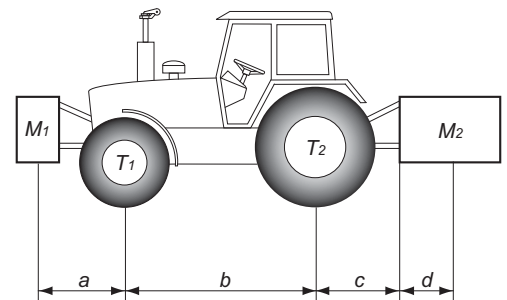

Description	Units	Description	Obtained by
T	kg	Tractor unladen weight	① ④
T1	kg	Unladen load on tractor front axle	① ④
T2	kg	Empty load on tractor rear axle	① ④
t	kg	Axle loads (Tractor + machine)	④
t1	kg	Load on front axle (Tractor + machine)	④
t2	kg	Load on rear axle (Tractor + machine)	④
M1	kg	Total weight of front tool or front ballast	② ④
M2	kg	Total weight of rear tool or rear ballast	② ④
a	m	Distance between the tools' centre of gravity or the front ballast and the front axle centre	② ③
b	m	Distance between the tractor axles	① ③
c	m	Distance between the rear axle center and the center of the lower link ball joints	① ③
d	m	Distance between the centre of the lower link ball joints and the centre of gravity of the rear tool or rear ballast	②

① Refer to the tractor operators' manual

② Refer to the machine price-list or operators' manual

③ Dimensions

④ Measure on scale

**Rear tool or front-rear combination:**

1) Calculation of the minimum front ballast weight  $M1_{\text{minimum}}$

$$M1_{\text{minimum}} = \frac{M2 \times (c+d) - T1 \times b + 0.2 \times T \times b}{a+b}$$

Write the minimal additional weight in the chart.



**Front tool:**

2) Calculation of the minimum rear ballast weight  $M2_{\text{minimum}}$

$$M2_{\text{minimum}} = \frac{M1 \times a - T2 \times b + 0.45 \times T \times b}{b+c+d}$$

Write the minimal additional weight in the chart.

3) Calculation of the actual load on the front axle  $T1_{\text{real}}$

If the front tool (M1) is lighter than the minimum load required at the front (minimum), increase tool weight until the required minimum front load is reached

$$T1_{\text{real}} = \frac{M1 \times (a+b) + T1 \times b - M2 \times (c+d)}{b}$$

Indicate front axle calculated load value and the one indicated in the tractor operators' manual.

4) Calculation of the total weight  $M_{\text{real}}$

If the rear tool (M2) is lighter than the minimum load required at the rear(minimum), increase tool weight until the required minimum rear load is reached

$$M_{\text{real}} = M1 + T + M2$$

Indicate calculated total load value and the one authorized as indicated in the tractor operator's manual.

5) Calculation of the actual rear axle load  $T2_{\text{real}}$

$$T2_{\text{real}} = M_{\text{real}} - T1_{\text{real}}$$

Indicate rear axle calculated load value and the one indicated in the tractor operator's manual.

6) Tyre carrying capacity

Indicate double (2 tyres) the authorized load value (see tyre manufacturer indications).

■ **Table:**

	Actual value obtained by calculation	Value authorized according to operator's manual	Double value of the authorized capacity per tyre (2 tyres)
Minimum front/rear ballasting	kg		
Total weight	kg	< kg	
Load on front axle	kg	< kg	< kg
Load on rear axle	kg	< kg	< kg

The minimum ballasting must be made by fitting a tool or an additional mass to the tractor.  
 The values obtained must be below or equal the authorized values.

■ **Determining the machine weight (M2) and the position of its centre of gravity (d)**



If the data required to calculate the total weight, axle loads and minimum ballasting are not supplied, use the following method.

- Tractor only:

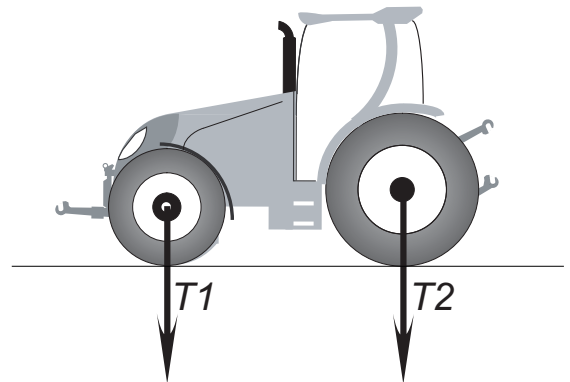

- T1: Load on front axle.  
• Tractor only.

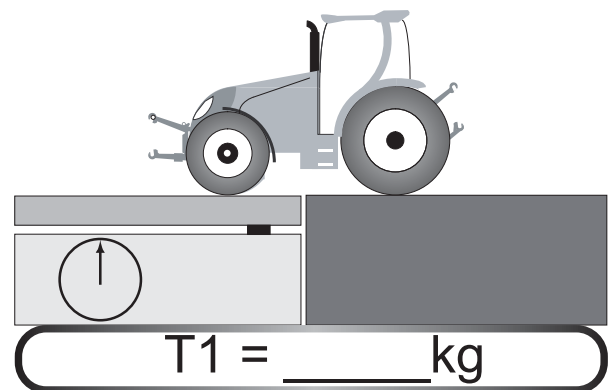

- T2: Load on rear axle.  
• Tractor only.

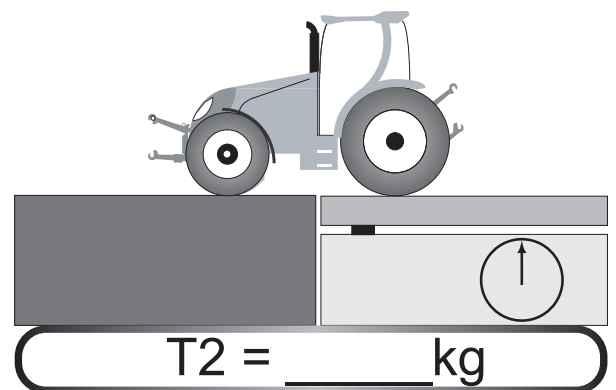

- T: Axle loads.
- Tractor only.

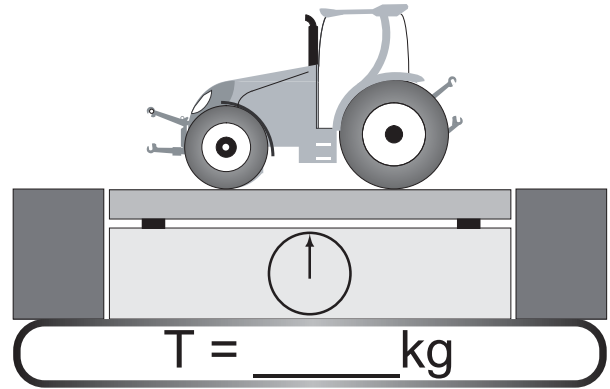

■ Rear tool or front-rear combination:



If the total unit weight exceeds the tractor Gross Combined Weight Rating in accordance with the country's legislation, empty the hopper to travel on public roads.

In any case, we recommend to travel on public roads with empty hoppers and tanks.

- Measure dimension (b).
- Measure dimension (c).

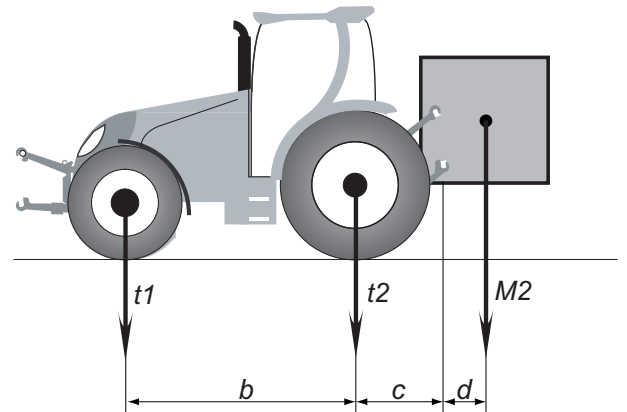

- t1: Load on front axle.
  - Tractor + machine.
  - Hopper empty!.

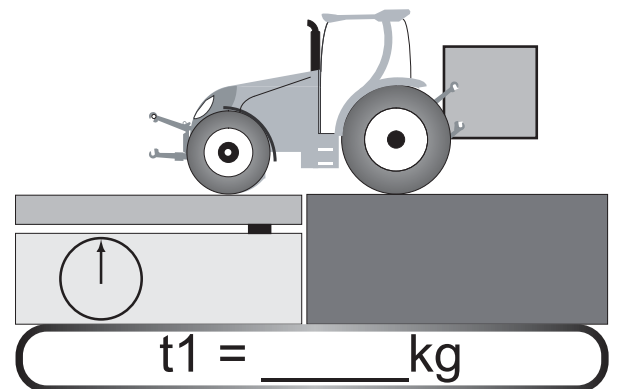

- t: Axle loads.
  - Tractor + machine.
  - Hopper empty!.

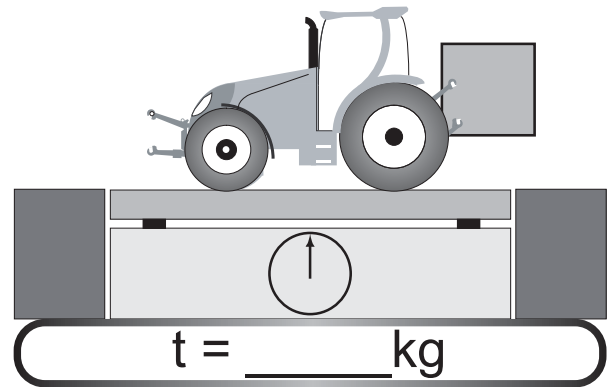

**Calculating the rear tool weight (M2):**

$$M2 = t - T$$

**Calculating the distance (d):**

$$d = ((b \times (T1 - t1)) / M2) - c$$

---

## 13. Limited Warranty

---

The **NOBILI S.p.A.** Via Circonvallazione Sud 46, 40062 Molinella (Bologna) Italia, according to the below-mentioned exceptions, certifies that its production is guaranteed against all defects of manufacture and material, on condition that it is used and treated complying with the instructions indicated in the use and maintenance handbook.

This guarantee lasts **12 (twelve)** months starting from the date of delivery to the user. This date will be verified through the postmark of the guarantee card filled in every part and sent to **NOBILI** company.

The guarantee is limited to the free supply ex works of the items found faulty by our technical services.

### Elements excluded from the guarantee conditions:

- Parts of the machine, not manufactured by **NOBILI** (such as: tyres, transmission belts, cardan transmissions, gear cases, etc.). They have only their manufacturers' guarantee.
- Parts whose deterioration is due to wear.

### Exceptions invalidating the guarantee:

- Changes carried out on the machine without **NOBILI** written permission.
- Reparations carried out in unauthorized workshops.
- Use of not original spare parts.
- Carelessness in maintenance.
- Use of the machine not according to what is indicated in the **use destination**.
- Removal of the guards placed on the machine: the guards should never be removed. They should be periodically checked and, if damaged, restored in their original conditions.
- Non-performance of safety instructions about the machine indicated in the use handbook.

### The **NOBILI** will disclaim all responsibility:

- For damages suffered or caused during the machine transport and unloading.
- For direct or indirect damages caused by the break of parts forming the machine or caused by the non-working of the machine itself.

### The user is in charge of:

- Normal maintenance of the machine, lubrication, keeping of oil levels, adjustments for use.
- Costs of transport and labour necessary for disassembling, re-assembling and adjusting parts which should be substituted under guarantee.

### Warranty demand:

The demand for guarantee should be written and sent to **NOBILI** by the seller, within 4 weeks since the damage occurred, indicating: user's name and address, type, model, serial number, date of sale, date of the failure, hours worked, supposed circumstances and causes.

The parts should be sent to **NOBILI** for being examined for granting the guarantee authorizing the replacement of the part.

### Changes:

The **NOBILI S.p.A.** reserves the right to carry out the changes it considers necessary on its production, without prior notice to the customers. It is not forced to change the machines already in use or on sale.

## Specimen of the “ Declaration of conformity ”

<b>NOBILI</b>	<b>Dichiarazione di conformità CE</b> alla direttiva 2006/42/CE <b>Déclaration CE de conformité</b> à la directive 2006/42/CE <b>EC declaration of conformity</b> to directive 2006/42/EC <b>EG-Konformitätserklärung</b> der Richtlinie 2006/42/EG
<b>NOBILI S.p.A.</b> Via Circonvallazione Sud, 46 - 40062 Molinella (BO) - ITALY Tel. +39 051.88.14.44 - FAX +39 051.88.27.03 - - http://www.nobili.com - info@nobili.com	
Depositario della documentazione: Dépositaire documentation: Documentation Depository: Verwahrer Dokumentation:	<b>Andrea Barilani - Nobili S.p.A.</b> Via Circonvallazione Sud, 46 - 40062 Molinella (BO) - ITALY
Dichiara che la macchina: Déclare que la machine: Declares that the machine: Erklärt, dass die Maschine:	<b>NOME MACCHINA</b> S/N: <b>NR SERIE</b> Year: <b>ANNO</b>
è conforme alla Direttiva Europea 2006/42/CE. Per l'adeguamento della macchina sono state consultate le seguenti Norme Armonizzate: EN ISO 4254-12:2012 - EN 13524:2014 - EN ISO 4254-6:2010 - EN ISO 4254-1:2013. Nonché le specifiche tecniche: ISO 11684:1995. <b>In caso di vendita della macchina, la presente dichiarazione deve essere consegnata all'acquirente.</b>	
est conforme aux dispositions de la Directive Européenne 2006/42/CE. Est conforme aux exigences des normes européennes harmonisées suivantes: EN ISO 4254-12:2012 - EN 13524:2014 - EN ISO 4254-6:2010 - EN ISO 4254-1:2013. Est conforme aux exigences des normes ou des spécifications techniques suivantes: ISO 11684:1995. <b>En cas de revente de la machine, la présente déclaration de conformité doit être remise à l'acheteur.</b>	
conforms to the requirements of the European Directive 2006/42/EC. Conforms to the requirements of following European harmonized standards: EN ISO 4254-12:2012 - EN 13524:2014 - EN ISO 4254-6:2010 - EN ISO 4254-1:2013. Conforms to the requirements of following standards or technical specifications: ISO 11684:1995. <b>In case of resale of the machine, this declaration of conformity must be given to the buyer.</b>	
Den Bestimmungen der Europäischen Richtlinie 2006/42/EG entspricht. Den Anforderungen folgender harmonisierten Normenweise entspricht: EN ISO 4254-12:2012 - EN 13524:2014 - EN ISO 4254-6:2010 - EN ISO 4254-1:2013. Den Anforderungen folgender Normenweise oder technischer Spezifikationen entspricht: ISO 11684:1995. <b>Bei Weiterverkauf der Maschine muss die Konformitätserklärung dem Käufer übergeben werden.</b>	
Responsabile della Sicurezza: Responsable Sécurité: Head of Safety: Sicherheitsleiter:	 Andrea Barilani Molinella (BO): GG/MM/AAAA



# NOBILI

*Il nome che conta*

**For your safety and the good working  
of your machines,  
use original NOBILI spare parts only**

RAPPRESENTATO DA:  
REPRESENTED BY:  
REPRESENTE PAR:  
VERTRETEN DURCH:



40062 MOLINELLA (BO) ITALY - Via Circonvallazione Sud, 46  
Tel. 051/88.14.44-45 - Telefax 051/88.27.03  
[www.nobili.com](http://www.nobili.com) - E-mail: [info@nobili.com](mailto:info@nobili.com)